



数字图像取证 的热点和研究进展

北京交通大学 倪蓉蓉

2017-12-7



汇报提纲

- 研究背景和研究对象
- 基于峰谷特性的图像对比度增强取证
- 基于局部描述子的鲁棒中值滤波取证
- 基于内容自适应融合残差网络的相机源辨别算法
- 基于卷积神经网络的小尺寸图像中值滤波检测
- 未来工作

研究背景和意义

- 大数据时代，多媒体信息丰富、传播速度快
- 图像、视频等视觉媒体的优点
 - 信息量大、感受直观



- 然而，图像修改、视频编辑等工具使用便捷。



Can we trust photos? 眼见为实 ? 不一定

- Is seeing believing now? Is the picture a real

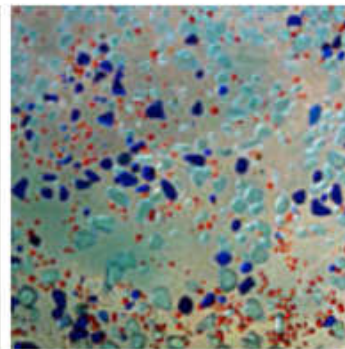

眼见不再为实

- Some changed images are for fun



US Presidential Election (2008)



Economical Crisis



Drew, Avi and Officer Fife collect 25 Million reward!



But, “malicious/intentional” manipulations will alter the semantic message.

Forged news picture

- Military Influence
 - Iraq War

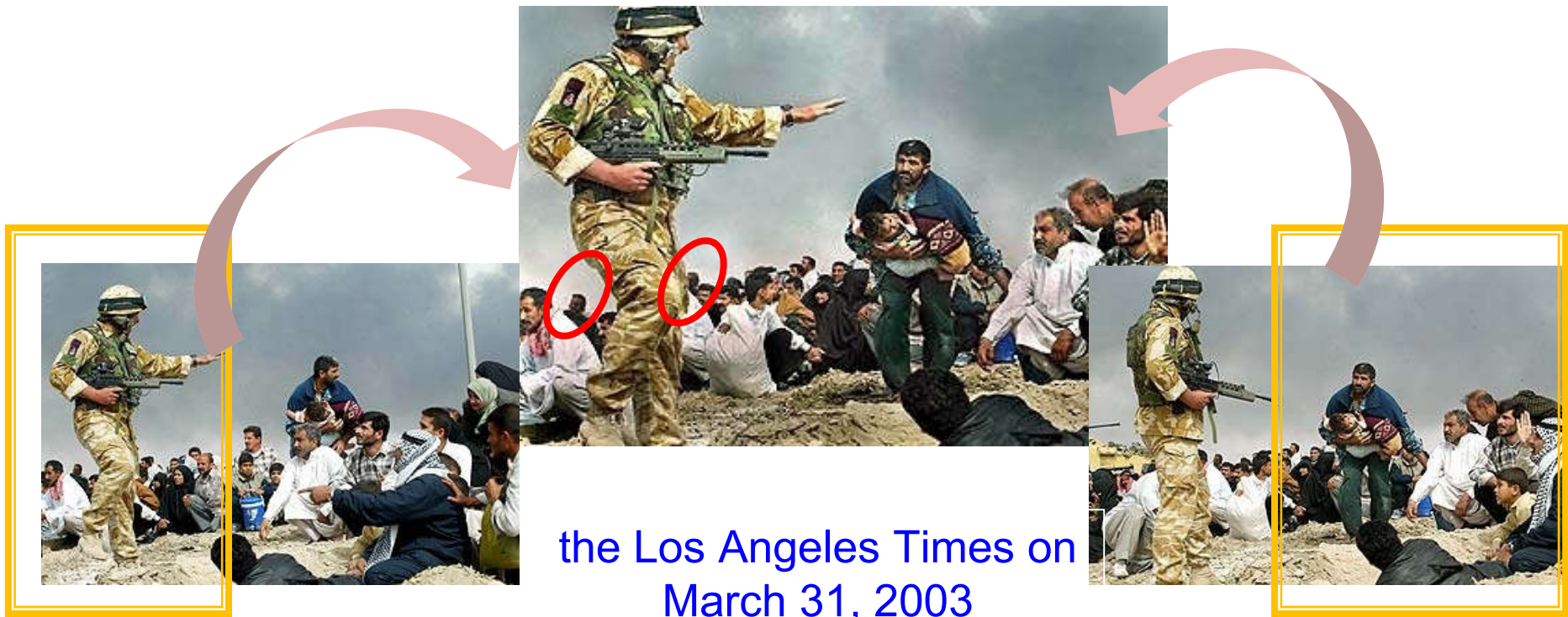

■ Military Influence

➤ Iran missile launch(2008)

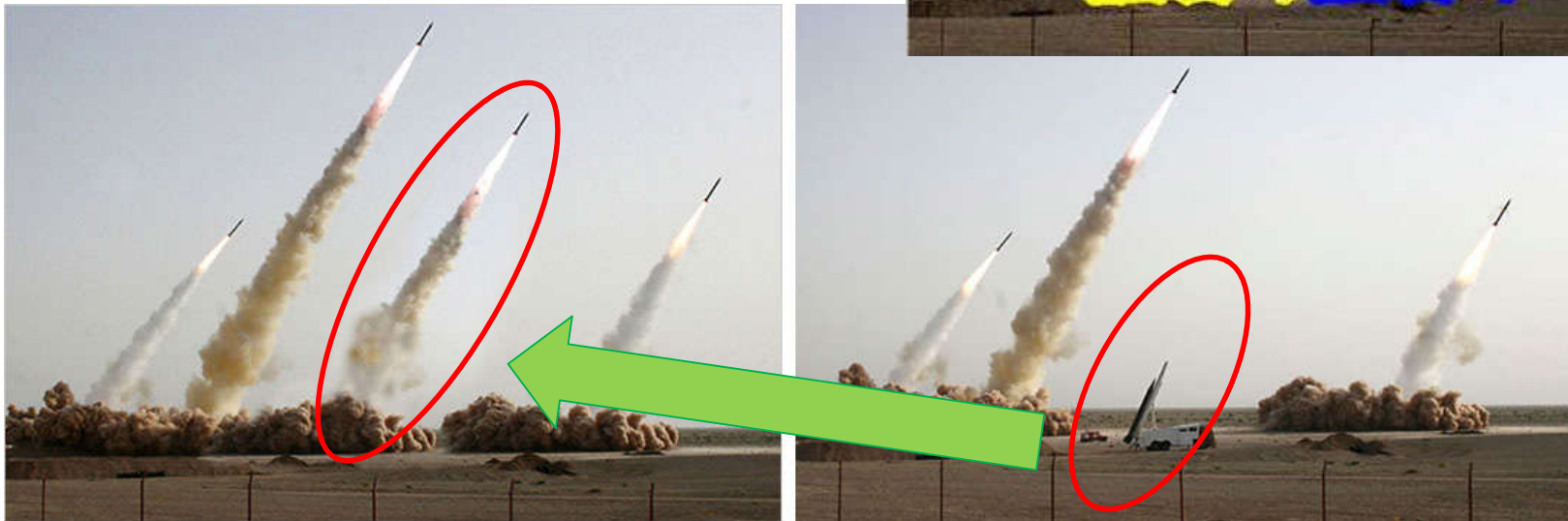

■ Political Influence

➤ President Election in USA



John Kerry and Jane Fonda were sharing a podium at an anti-Vietnam-war rally? (2004)

■ Political Influence

➤ Tibet issues



Cropping cause a different opinion

An Iraq war photo



Cropped
version I

Original

Cropped
version II

http://www.i-am-bored.com/bored_link.cfm?link_id=49206

■ Science Influence

➤ Southern China Tiger

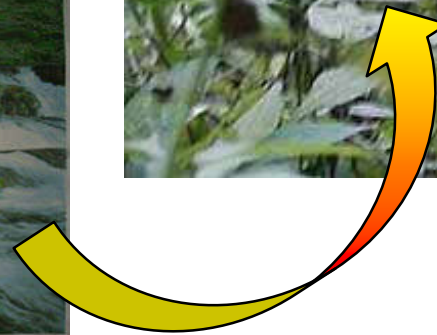

美国《科学》杂志刊登的华南虎事件详细内容

<http://www.aweb.com.cn> 2007年11月09日 11:21 农博网

Famous Journal
《Science》
reports this
forgery case.



Flat cat?

Rare-Tiger Photo Flap Makes Fur Fly in China

A few weeks ago, tiger researchers celebrated the news that a South China tiger (*Panthera tigris amoyensis*) had been spotted—and photographed—in the wilds of Shaanxi Province. But netizens in China and elsewhere have declared it only a “paper tiger” after scrutinizing the two available images.

Although the species has been declared “functionally extinct,” reports of tiger activity in the heavily forested Qinba Mountains prompted Shaanxi officials to offer a reward to anyone able to photograph one of the tigers.

At a 12 October press conference in Xian, Zhou Zhenglong, a former hunter, told a rapt audience of his quest to photograph the beast.

tame-looking expression and unreal coat color—as well as the fact that the two photos portray exactly the same tiger but differently positioned foliage—think it’s more likely that someone planted a cardboard tiger in the bushes. Fu Dezhi, a botanist at the Chinese Academy of Sciences, adds that the plants are not to scale in relation to the tiger. Zhou, who was paid 20,000 yuan (\$2666) for the images, says, “I guarantee with my head that the photographs are authentic.”

The Shaanxi Forestry Bureau is pushing ahead with plans for a thorough survey and a tiger reserve. “It’s tremendously exciting news, if it can be substantiated,” says tiger expert Gary Koehler of Washington state’s Department of Fish and Wildlife (*Science*, 7 September, p. 1312). But first, “they need to look for hair snags or scat” for genetic verification.

Lean Times for Lake Superior

This fall, the water level of Lake Superior, the world’s largest freshwater lake, dipped below the record it set in the Dust Bowl days of 1926.

RANDOMSAMPLES

EDITED BY CONSTANCE HOLDEN

after several weeks of rain but was still 30 cm below the long-term average. Boats are resting on mud, docks are poking nothing but air, and fishermen and lakeside rice growers are watching their livelihoods dry up.

Some factors that explain the mess: The surface temperature of the lake has mysteriously risen 4.5°C since 1978—twice as fast as the temperature of the surrounding air. Ice, which blocks evaporation, has become rare on Superior, and precipitation has dropped 15 cm a year from the annual average of 77 cm.

But the big picture remains unclear. “We know how it’s happening, but the why—I don’t know,” says hydrologist Cynthia Sellinger of the National Oceanic and Atmospheric Administration. One reason, experts say, is that climate models aren’t very good at predicting greenhouse effects at regional scales.

<< Micromini Radio

A carbon nanotube 10,000 times as thin as a human hair turns radio waves into music, acting like a tiny radio, in this image (wavy lines added) taken by researchers at the University of California, Irvine.

AM radio waves cause the tube to vibrate; then an electric field forces electrons—that is, an electrical current—out of its tip. The current detects the vibrations, converting the waves to sound. This month in *Nano Letters*, Peter Burke and Christopher Rutherglen report using the device to transmit music wirelessly almost a meter



News Awards are exposed as the tampered images



Tibet railway and the wild animals



Plaza peace dove

- The effect of image composite is very realistic



Is it a
real
scene
image?

- Actually,



➤ Multiple Images and multiple operations composition



Top: Original images, Bottom: composite image



Defense Advanced Research Projects Agency
675 North Randolph Street
Arlington, VA 22203-2114

Contract Research and Development

R&D Business Opportunity Abstracts

HOME ABOUT BAAS SBIRS GRANTS AWARDS SPONSOR

DARPA Media Forensics (MediFor) Proposers Day

[Leave a reply](#)

DARPA Information Innovation Office (I2O) has [announced](#) a Proposers Day for the Media Forensics (MediFor) program. The Proposers Day will be held on Friday, October 2, 2015, from 10:00 AM to 2:00 PM (ET) at the DARPA Conference Center located at 675 N. Randolph Street, Arlington, Virginia, 22203. Advance registration is required at <https://www.schafertm.com/darpa/i2o/medifor/pd/> no later than 8:00 AM (ET) on September 30, 2015.

The MediFor program will develop “technologies for the automated assessment of the authenticity of an image or video. The program will integrate these technologies in a visual media forensics platform that, for a given image/video, will automatically detect manipulations, provide decision makers with detailed information about the types of manipulations performed, and their significance/importance in order to facilitate decision-making regarding the intelligence value of the image/video. The MediFor platform will also automatically discover associations across visual media collections as another means for confirming the authenticity of an image/video.”

More information is available in the special notice [DARPA-SN-15-77](#).



DARPA wants better detection of doctored images

By Mark Pomerleau | Sep 22, 2015

With image manipulation technology readily available to the general public, the number of “enhanced” images has dramatically increased. But before government analysts can evaluate the content of images and video uploaded to social media, it must be able to identify those that have been altered.

To address this need, the Defense Advanced Research Projects Agency announced a proposer’s day to discuss objectives of the anticipated release the Media Forensics (MediaFor) [broad agency announcement](#).

In one of the most famous examples of [photo manipulation](#), Iran produced a photograph in 2008 that purported to show a “provocative” missile test launch. While the photo was discovered to be a Photoshopped hoax, the image ran on the front page of American newspapers before that determination was made.

Because there are few tools for image manipulation detection available in the commercial sector, media forensics analysts rely heavily on their own background and

顶会和竞赛

CVPR Workshop on Media Forensics

July 26th, 2017 @ Honolulu, Hawaii

(2017.06.02) There is a slight update to the program.

Call for Participation

This workshop will focus on the role of computer vision and pattern recognition in forensic applications, with special emphasis on media forensics. There are a number of areas in the computer vision and pattern recognition field that can contribute to the forensics community. These include algorithms for automated analysis of forensics, tools to assist forensic examiners, and methodologies for assessing the accuracy of tools and forensic examiners. Topics of interest include, but are not limited to:

- Media forensics
 - detection of forged and manipulated images, documents and video,
 - discrimination between computer graphics and photographic images,
 - reconstruction of media genealogy;
- Analysis and recognition of
 - blood splatters,
 - bite marks,
 - tool marks;
- Analysis and recognition of 2D and 3D patterns
 - on bullets and their casings,
 - shoe and tire impressions;
- 3D reconstruction of crime scenes,

The workshop will allow for a broad discussion of forensic-related issues across these topics.

Program

Time	Title	Speaker/Author(s)
08:50	Welcome	Conference Chairs
09:00	Keynote: Photo Forensics from JPEG Coding Artifacts	Hany Farid (Dartmouth College)
Session 1: Face Image Forensics (09:50-10:10) Session Chair: Larry Davis		
09:50	Position Determines Perspective: Investigating Perspective Distortion for Image Forensics of Faces	Bo Peng, Wei Wang, Jing Dong, Tieniu Tan
10:10	Morning Break	
Session 2: Neural Networks & Camera Identification (10:40-12:00) Session Chair: Hany Farid		
10:40	Transferable Deep-CNN features for detecting digital and print-scanned morphed face images	Raghavendra Ramachandra, Kiran Raja, Sushma Venkatesh, Christoph Busc
11:00	Localization of JPEG double compression through multi-domain convolutional neural networks	Irene Amerini, Tiberio Uricchio, Lamberto Ballan, Roberto Caldelli

Media Forensics Challenge



The objective of the Media Forensics evaluation series is to support research in, and help advance the state of the art of, image forensics technologies - technologies that determine the region and type of manipulation in a given image. This annual series of evaluations will provide the community with rich resources to aid in the development of the technology.

The first Media Forensics evaluation took place in the summer of 2017 ([NC2017](#)). To prepare for this evaluation, NIST created a pilot data set, the Nimble Challenge '16 (NC2016) data set, which is available upon request via the contact below. The second Media Forensics evaluation ([MFC2018](#)) is currently being designed using our experience from NC2017.

Perspective Media Forensics participants can subscribe to the Media Forensics mailing list for announcements by sending a request to the contact below.

Contact

mfc_poc@nist.gov (link sends e-mail)



图像取证的研究对象

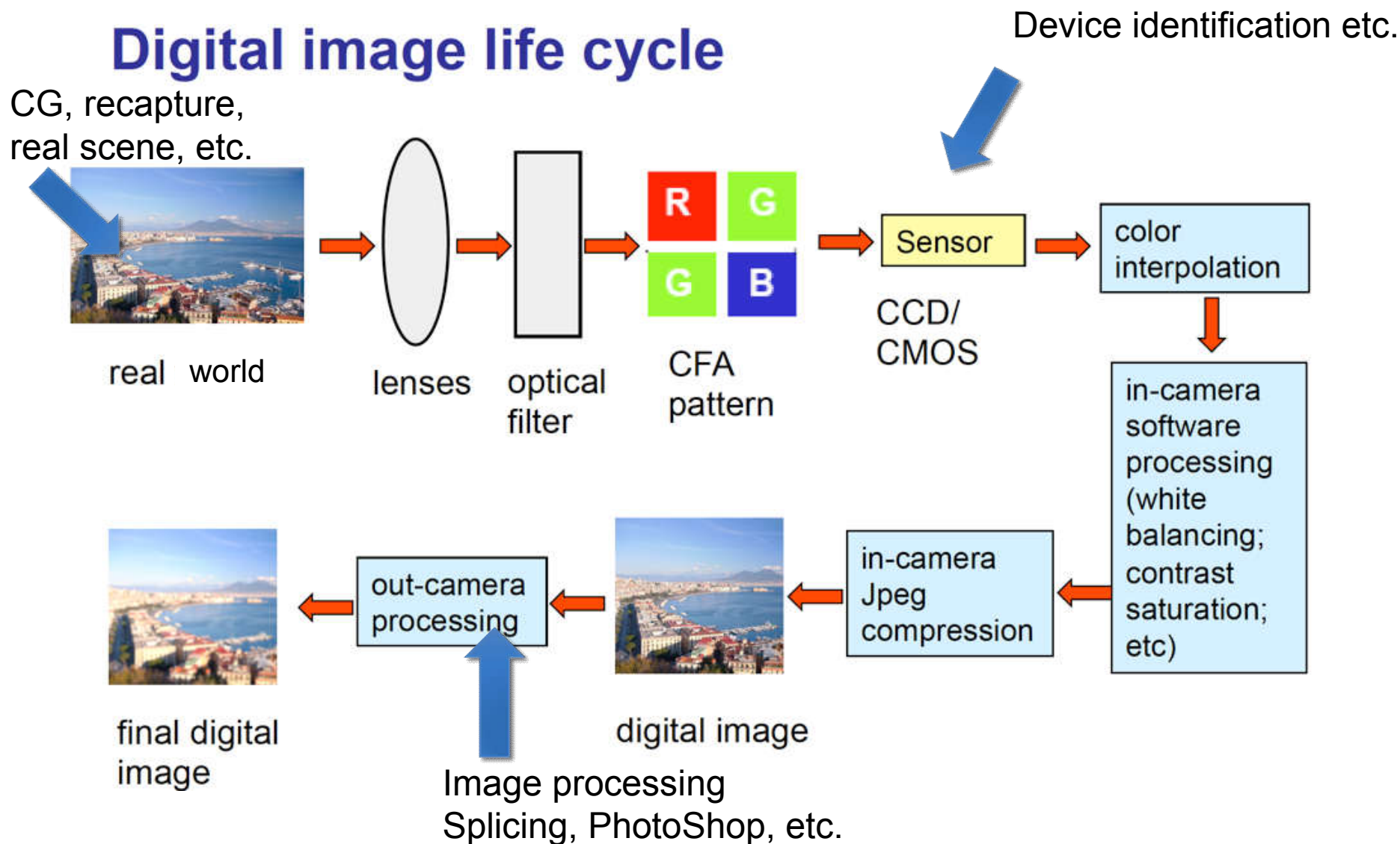



图像取证的研究对象

- Camera based
 - Chromatic aberration
 - CFA
 - Camera response
 - Sensor noise
- Physical based
 - Light direction
 - Light environment
 - Geometric or perspective consistence



图像取证的研究对象

- Source origin
 - Real scene, CG picture, recaptured image
- Device identification
 - Camera brand and type, scanner brand
- Operation forensics
 - Processing type, operation history
 - Double Jpeg, resampling, filtering, seamcarving, etc.
- Splicing forensics
 - Cloning, copy-move, cut-paste



汇报提纲

- 研究背景和研究对象
- 基于峰谷特性的图像对比度增强取证
- 基于局部描述子的鲁棒中值滤波取证
- 基于内容自适应融合残差网络的相机源辨别算法
- 基于卷积神经网络的小尺寸图像中值滤波检测
- 未来工作

对比度增强及引起的峰谷效应

➤ contrast enhancement = pixel mapping

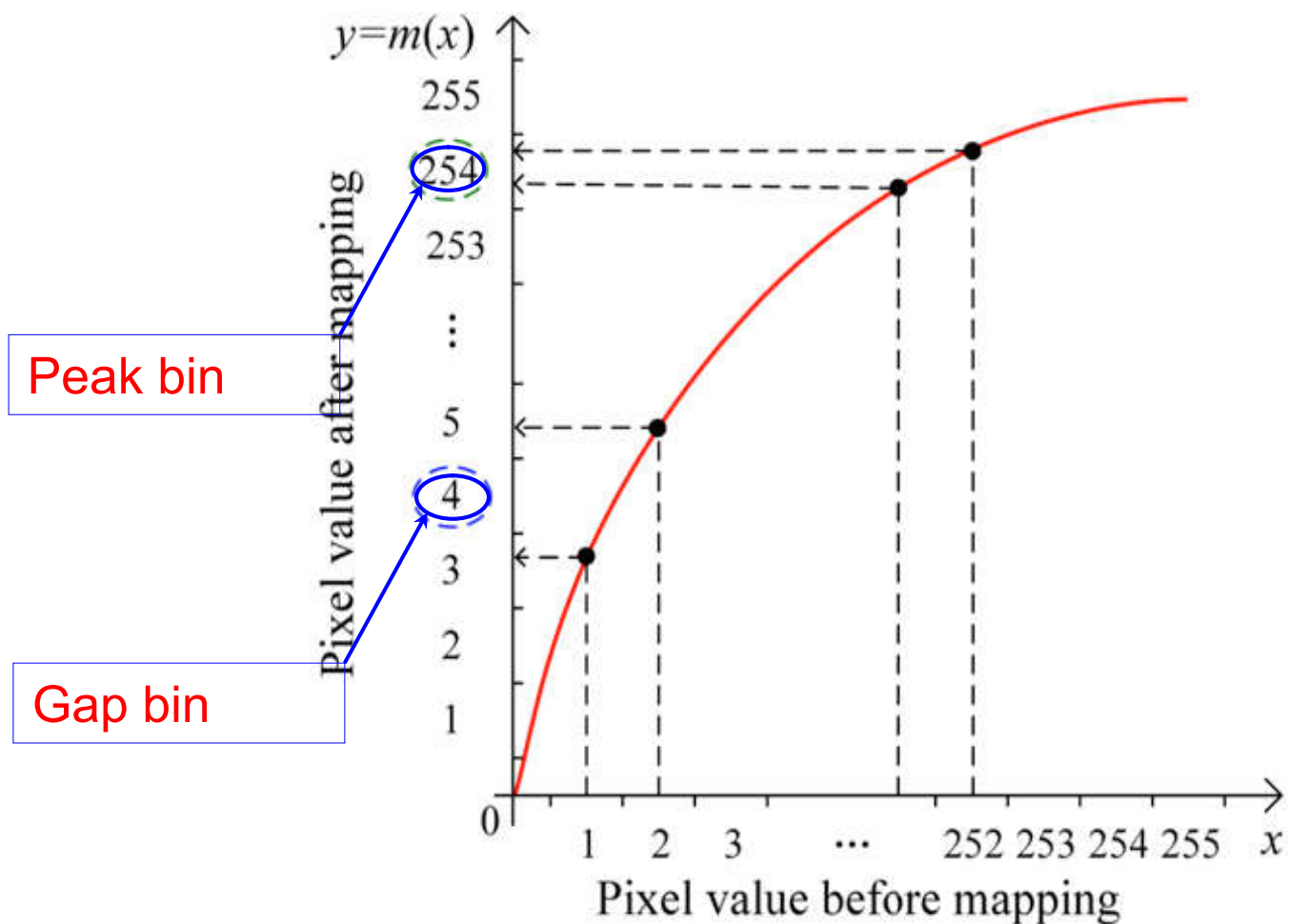



典型方法及问题

- Capture the peak and gap characteristics
- ✓ M. Stamm and K. J. R. Liu, “Blind Forensics of Contrast Enhancement in Digital Images,” ICIP, 2008.
- ✓ M. Stamm and K. J. R. Liu. Forensic detection of image manipulation using statistical intrinsic fingerprints. IEEE Trans. on Information Forensics and Security (TIFS). 2010, 5(3): 492-506
- ✓ M. Stamm and K. J. R. Liu, “Forensic Estimation and Reconstruction of a Contrast Enhancement Mapping,” ICASSP, 2010.

Peak-Gap effect for natural image

unaltered image

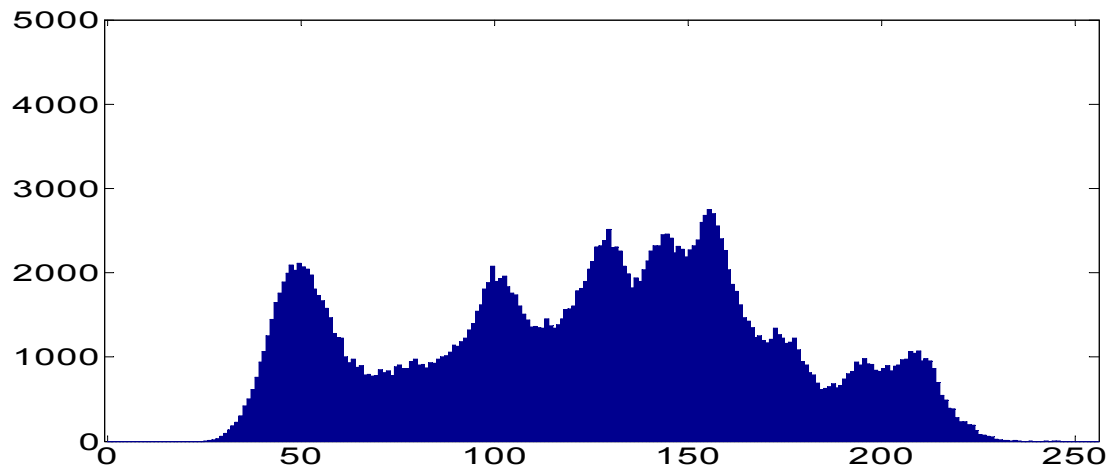

$\gamma = 1.2$

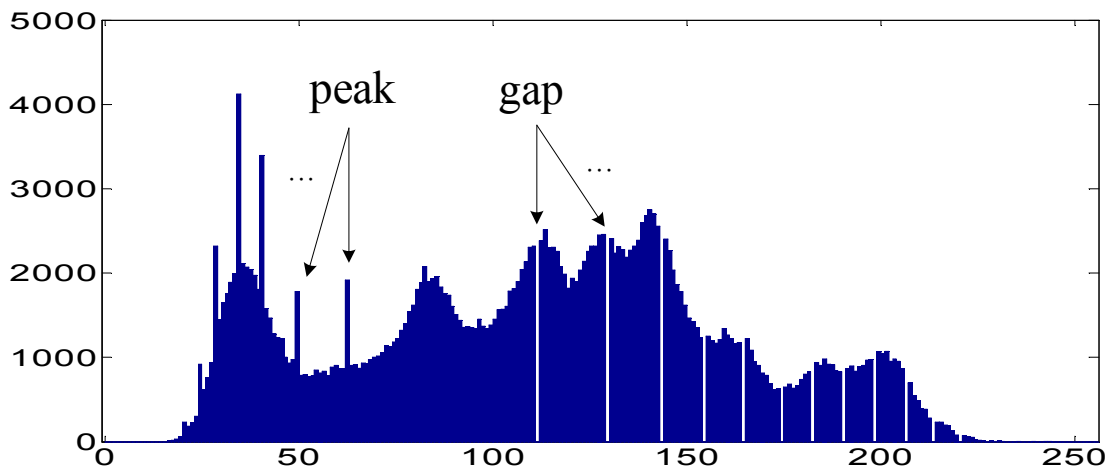

Undetectable case

- Problem for low-quality JPEG images ($Q < 70$)

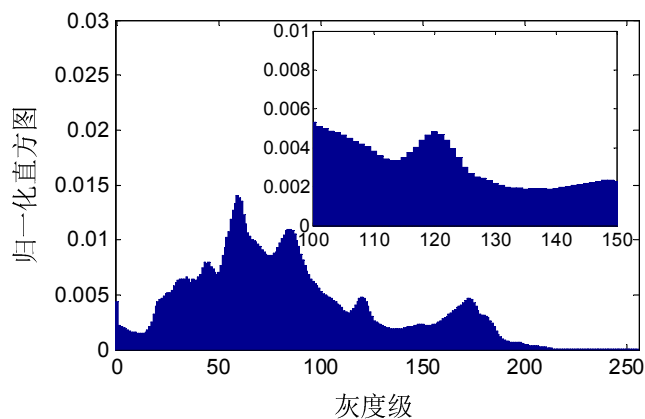

Raw image

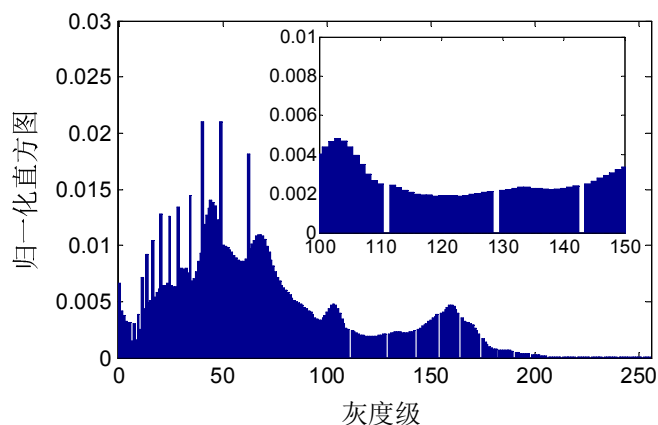

Contrast enhancement ($r=1.2$)

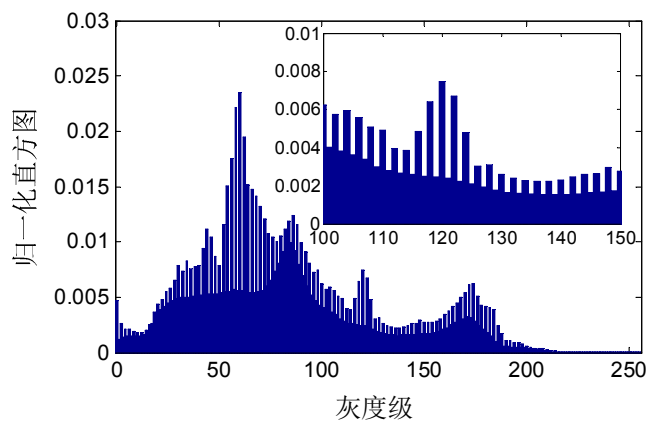

JPEG version($Q=50$)

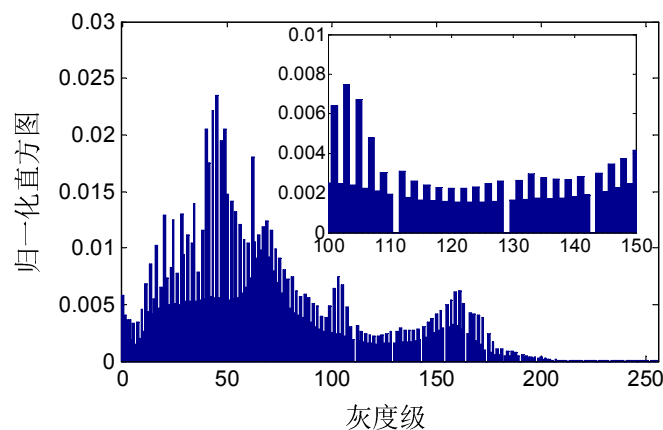

JPEG followed by contrast enhancement

Detection of global contrast enhancement

- Define a zero-height gap
- Discriminate from the gap induced by low-quality JPEG compression

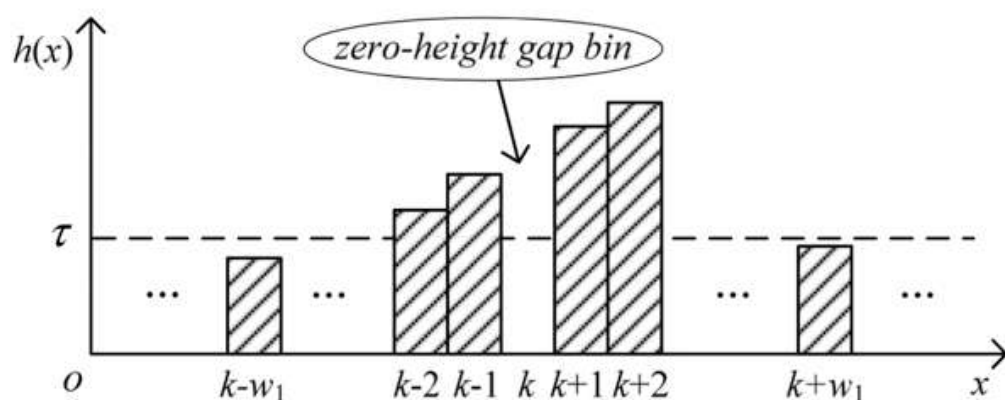

Zero-height gap bin at k

$$\begin{cases} h(k) = 0 \\ \min \{h(k-1), h(k+1)\} > \tau \\ \frac{1}{2w_1 + 1} \sum_{x=k-w_1}^{k+w_1} h(x) > \tau \end{cases}$$

the number of zero-height gap bin is regarded as the feature

Detection of splicing image

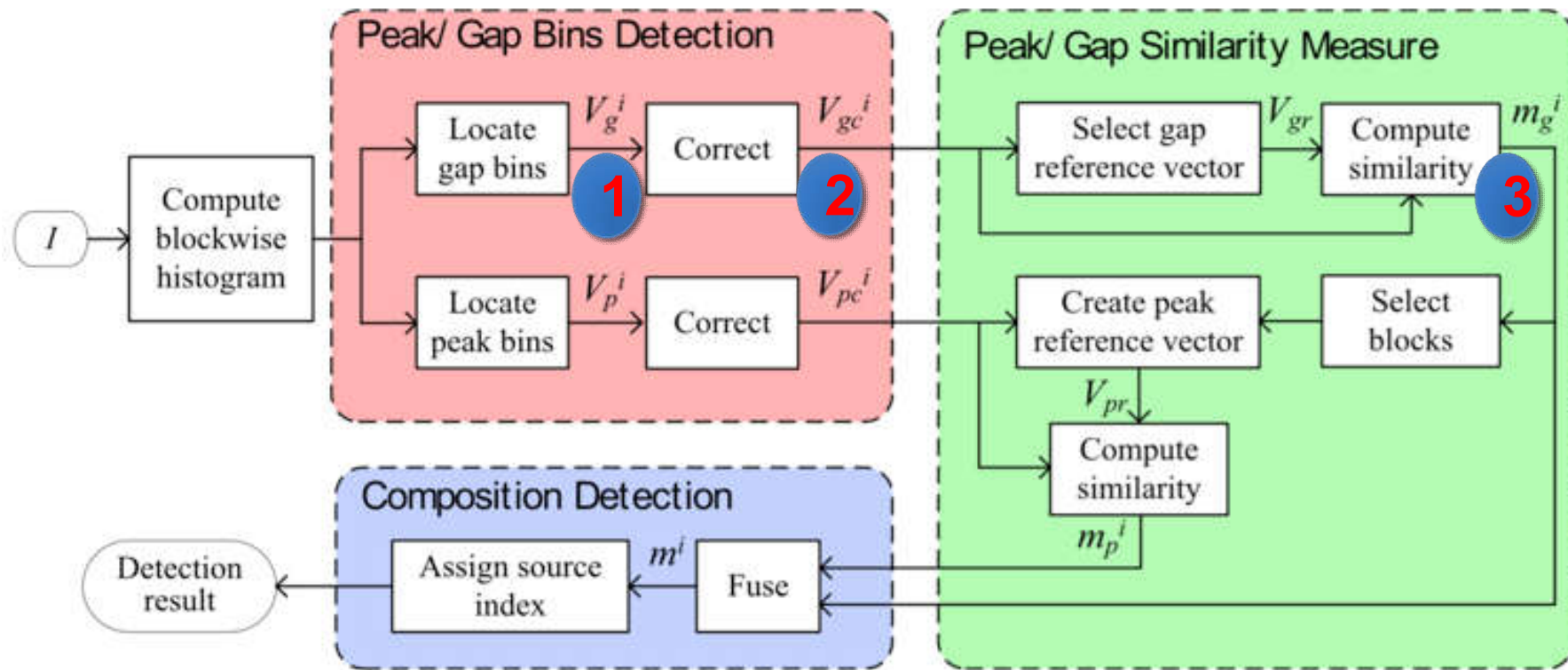

Flowchart of composite image detection



Some details

1-Obtain the position vector

$$V_g^i = [V_g^i(0), V_g^i(1), \dots, V_g^i(k), \dots, V_g^i(255)]$$

2-Correct the position vector

co-existing peak/ gap positions in most blocks are remained as a compared vector V_g

$$V_{gc}^i = V_g^i \odot V_g$$



3-Calculate the similarity with reference position vector
 the block with the largest number of zero-height gap bins
 is believed to locate within one source region, not the
 splicing boundary. It is selected as the reference vector.

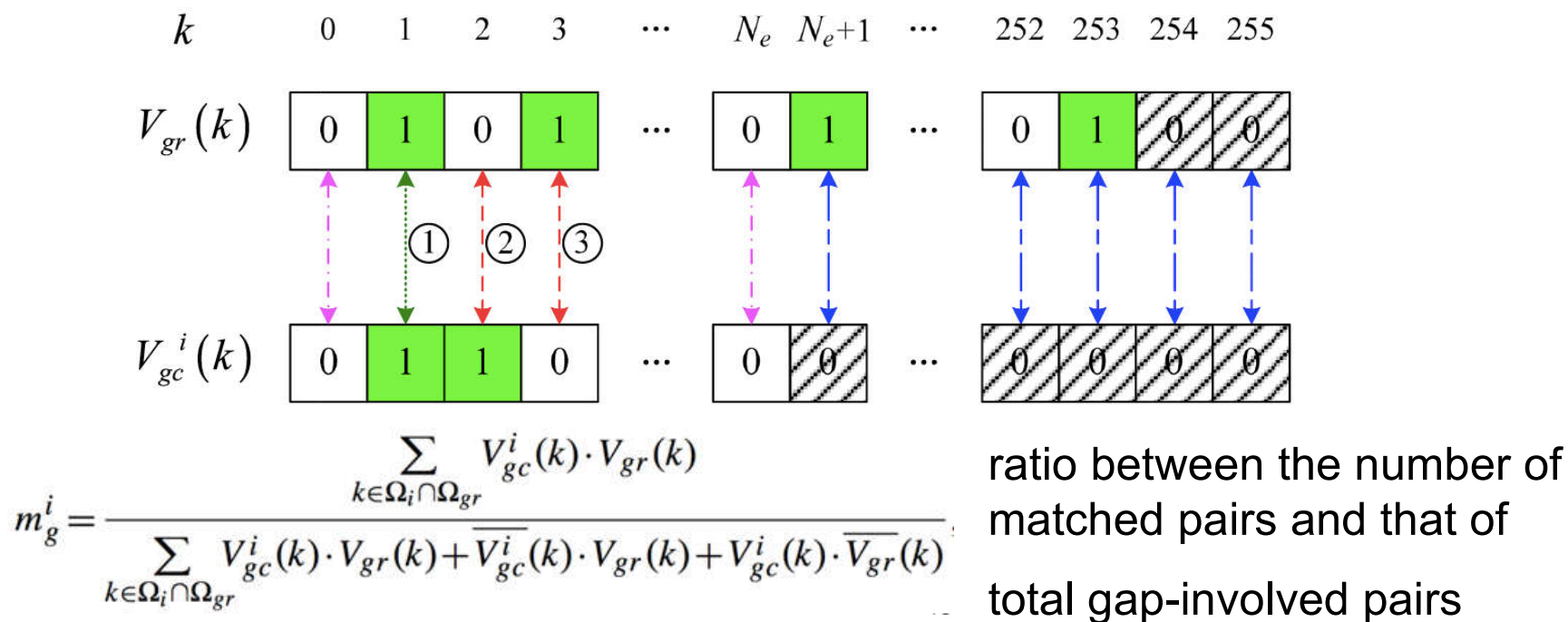

Detection of splicing image

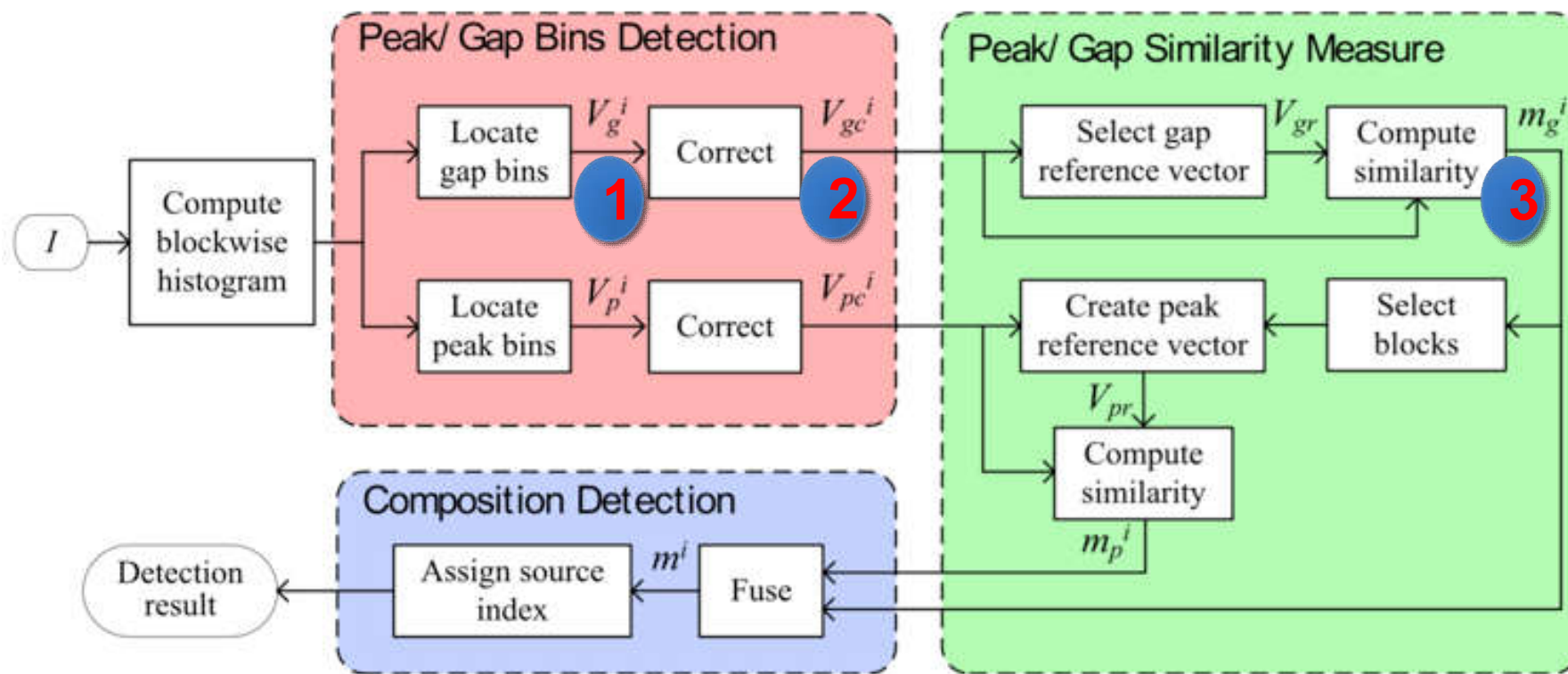

峰、谷的特征向量融合

Flowchart of composite image detection



Experiments

➤ Test Data

- Dataset 1: 800 unaltered photograph images in raw format, resolution is $2000 \times 3008 \sim 5212 \times 3468$ pixels
- Dataset 2: UCID image dataset, 1338 uncompressed images, resolution is $512 \times 384 \sim 384 \times 512$ pixels
- Dataset 3: 1100 JPEG format images, resolution is $1200 \times 900 \sim 2832 \times 2128$ pixels

➤ Performance measurement: ROC curve



Global contrast enhancement (1/3)

➤ Detection performance @ Dataset 1

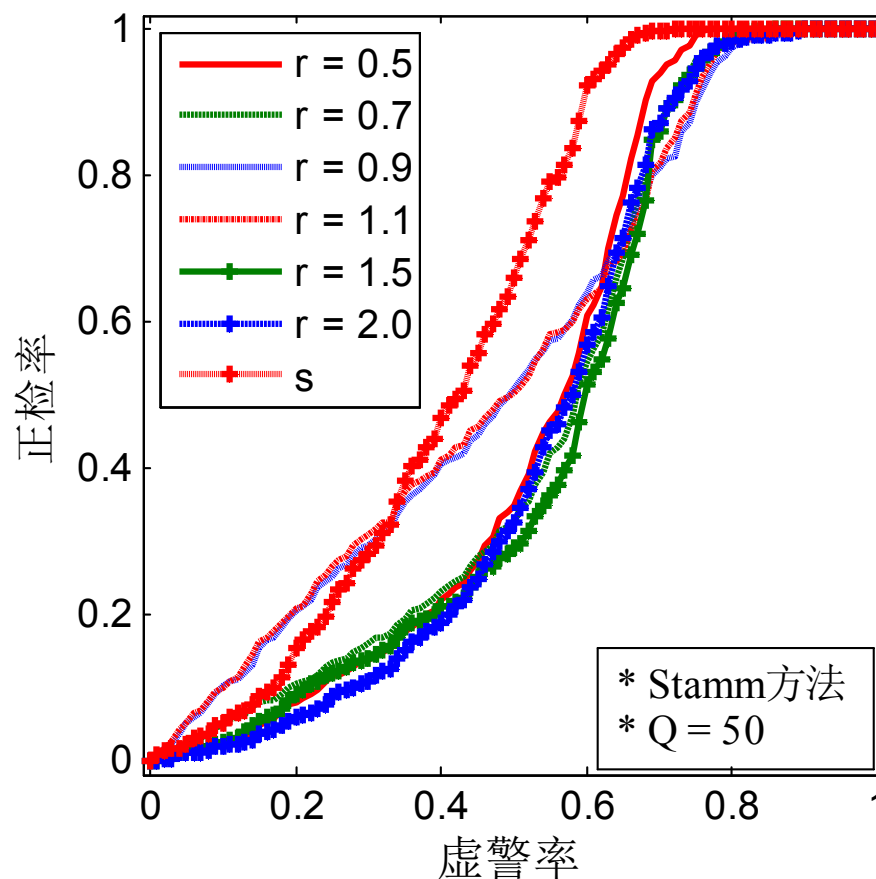
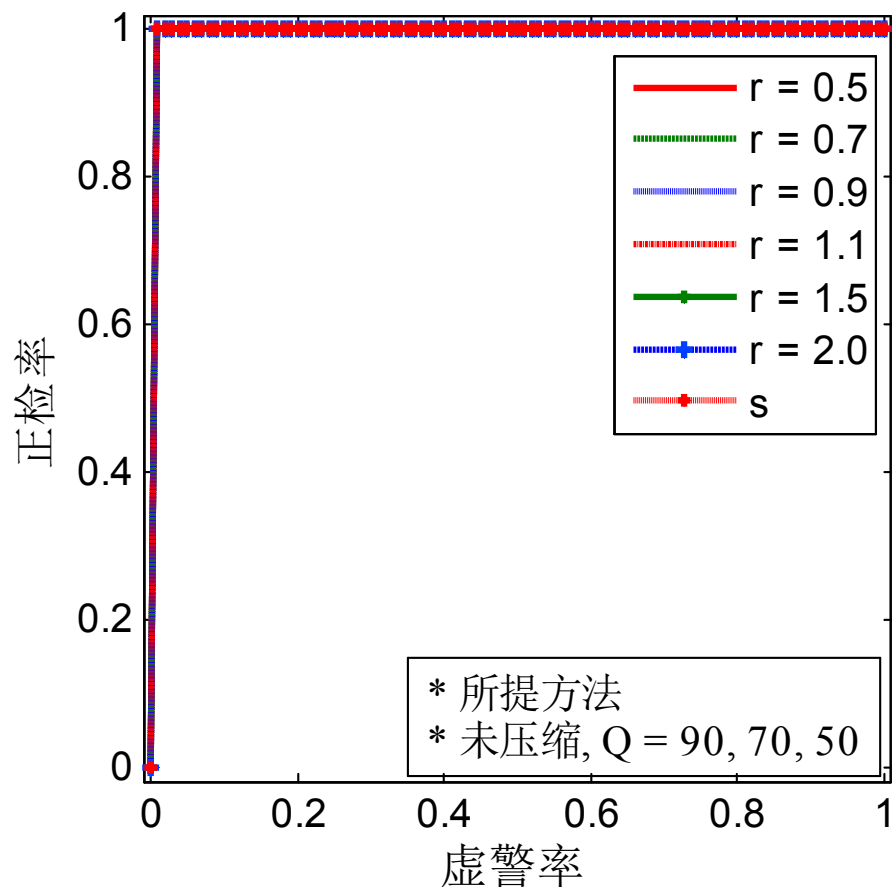



Global contrast enhancement (2/3)

➤ Detection performance @ Dataset 2

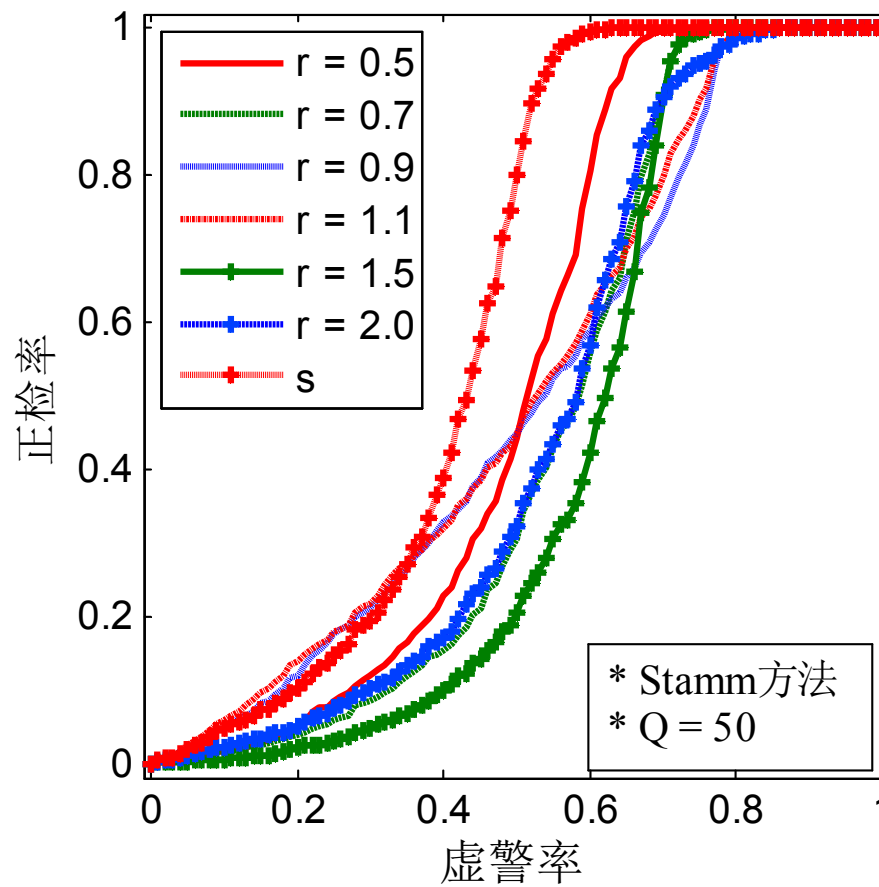
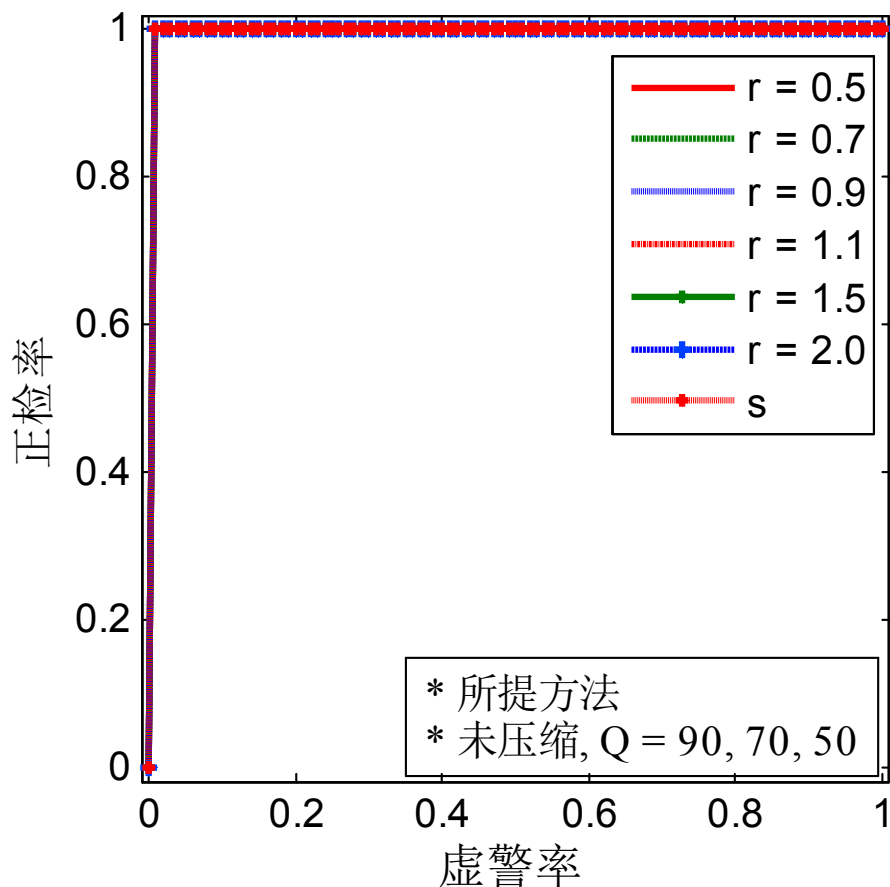

Global contrast enhancement (3/3)

➤ Detection performance @ Dataset 3

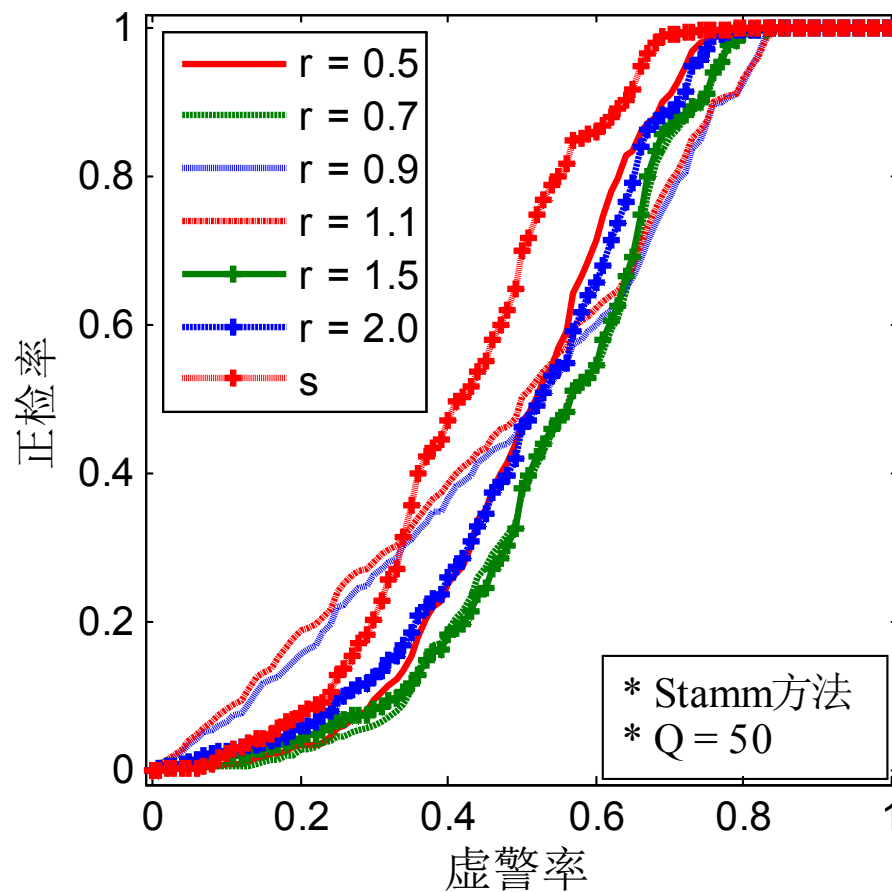
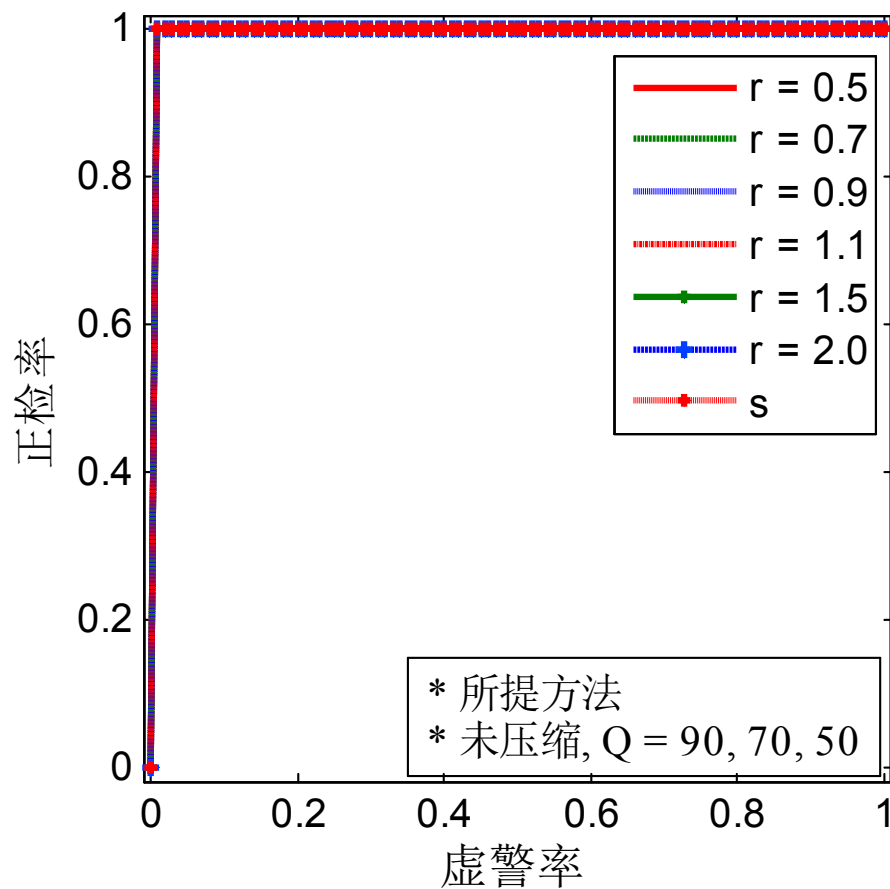

Detection of splicing image

➤ splicing example



Original image 1



original image 2



composite image

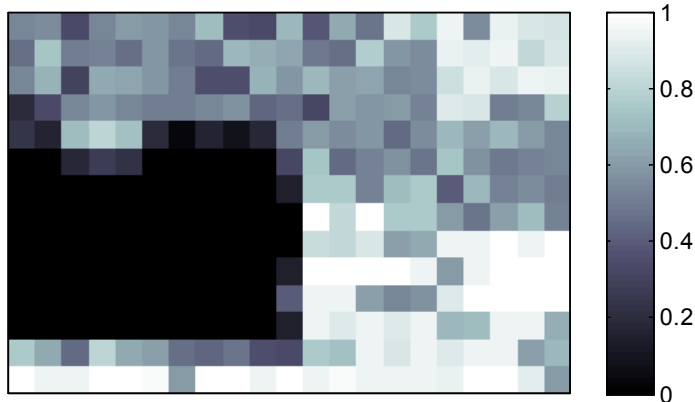

Our method

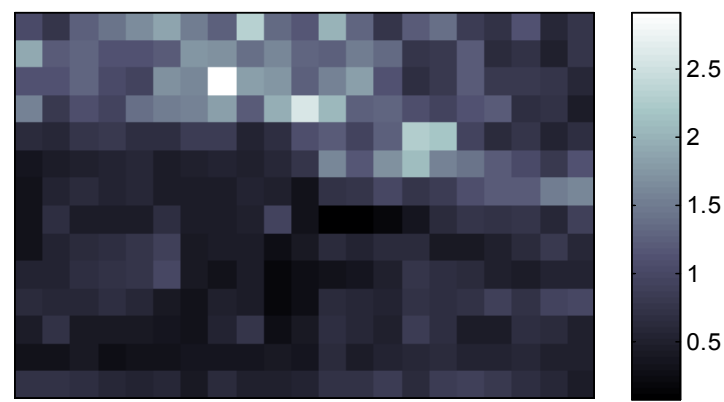

Stamm method

研究内容：基于峰谷特性的图像对比度增强取证 对比度增强和JPEG都会引起peak/gap效应

发表于IEEE
Trans. on IFS

但有明显差异，尤其与重度JPEG压缩相比

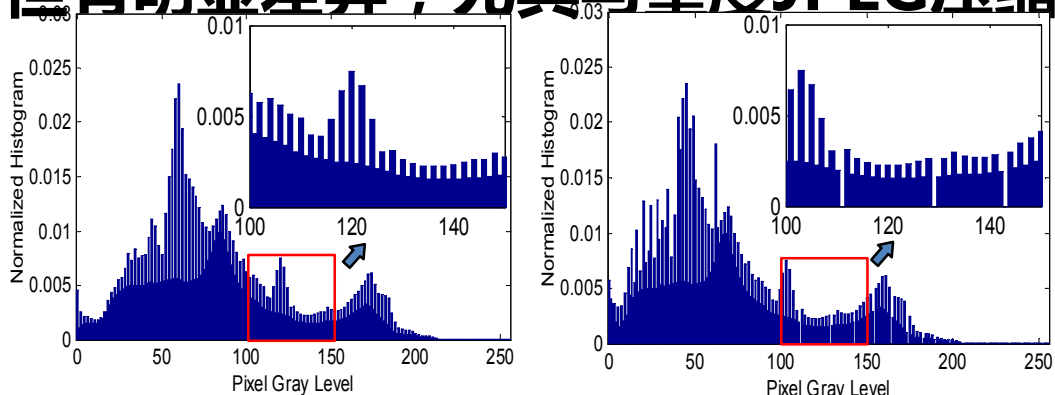

进而，定义和矫正了检测特征向量，提出拼接检测方法

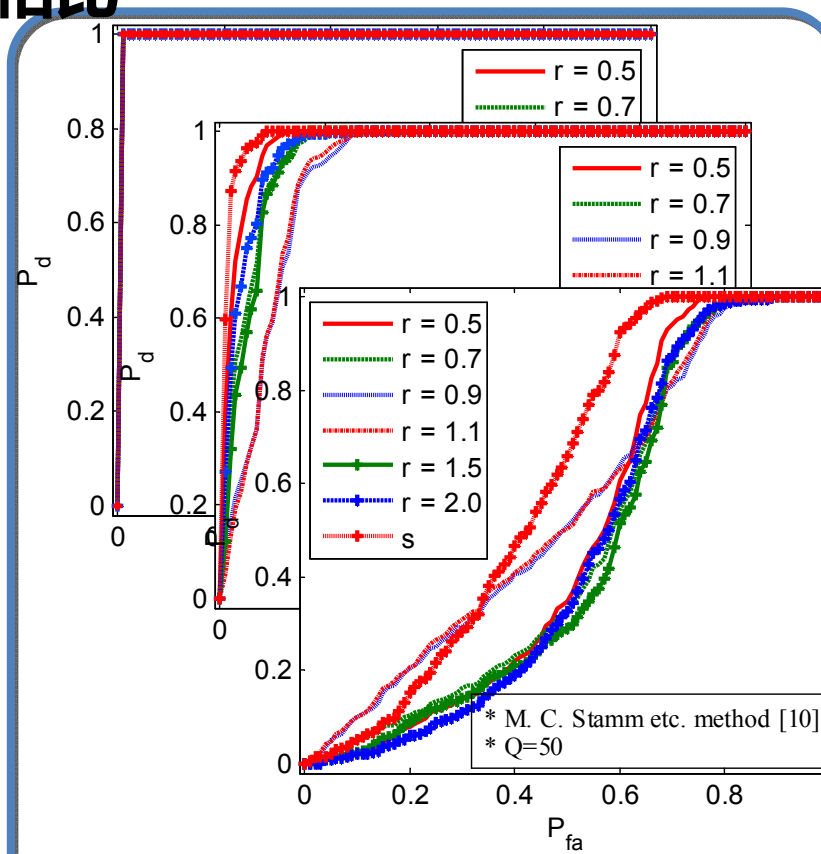
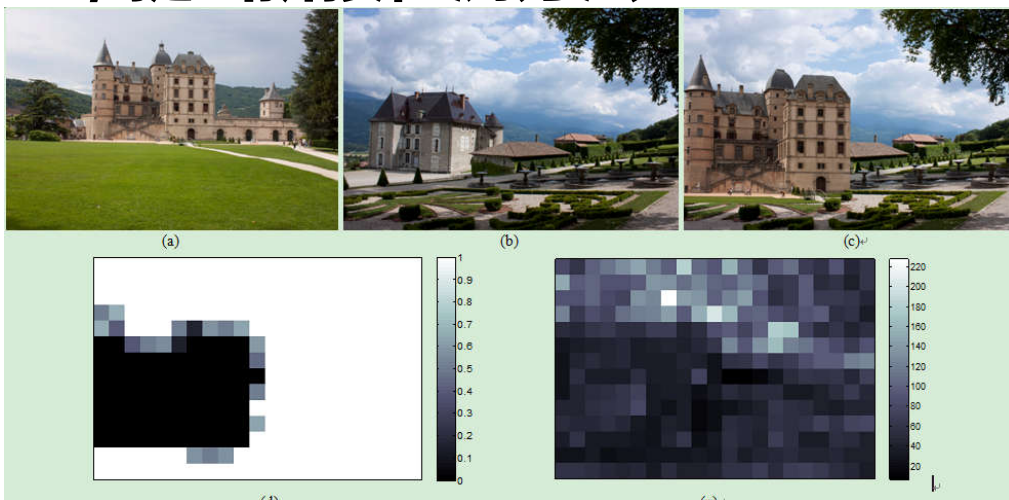

全局检测的ROC曲线及对比



汇报提纲

- 研究背景和研究对象
- 基于峰谷特性的图像对比度增强取证
- 基于局部描述子的鲁棒中值滤波取证
- 基于内容自适应融合残差网络的相机源辨别算法
- 基于卷积神经网络的小尺寸图像中值滤波检测
- 未来工作



中值滤波检测方法存在的问题

- 没有充分利用图像的局部纹理信息；
 - 对小尺寸图像和低质量JPEG压缩图像的鲁棒性较弱。
-
- ✓ C. Chen, J. Ni, and J. Huang, “Blind detection of median filtering in digital images: A difference domain based approach,” IEEE Transactions on Image Processing, 2013, 22(12):4699-4710.
 - ✓ X. Kang, M. C. Stamm, A. Peng, and K. R. Liu, “Robust median filtering forensics using an autoregressive model,” IEEE Transactions on Information Forensics and Security, 2013, 8(9):1456-1468.
 - ✓ Y. Zhang, S. Li, S. Wang, and Y. Q. Shi, “Revealing the traces of median filtering using high-order local ternary patterns,” IEEE Signal Processing Letters, vol, 2014, 21(3):275-279.



两类局部描述子

- 中值滤波具有保留边缘和平滑的性质。中值滤波后图像局部纹理统计特征会发生变化，例如边缘，明暗点，平滑统计特征；
- 中心位置像素值由中值替换，中心像素与相邻像素的值的
关系会改变。

局部描述子包括：融合的等价旋转不变LBP和差分矩阵相关系数特征。

- 等价旋转不变LBP：统计局部纹理特征
- 差分矩阵相关系数：描述相邻像素值关系

等价旋转不变LBP

$$LBP_{P,R}^{riu2} = \begin{cases} \sum_{p=0}^{P-1} s(g_p - g_c), & \text{if } U(LBP_{P,R}) \leq 2 \\ P + 1, & \text{otherwise} \end{cases}$$

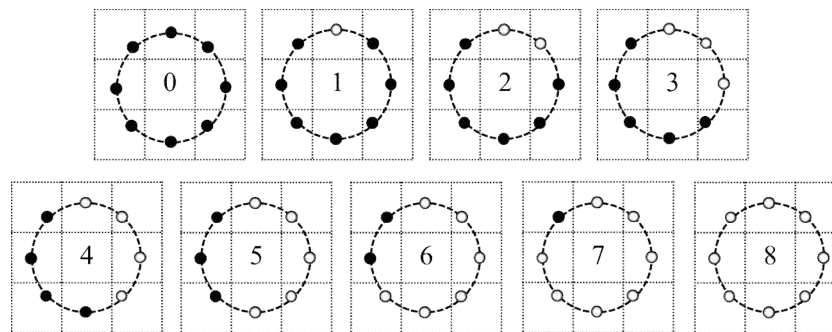

等价旋转不变LBP

10000幅原始图像与中值滤波图像的
等价旋转不变LBP直方图对比

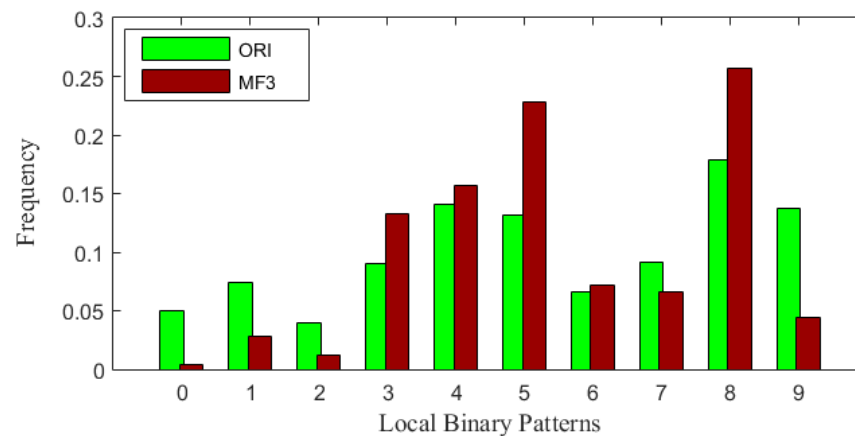

像素差分矩阵相关系数

相邻像素差分对构成像素差分矩阵

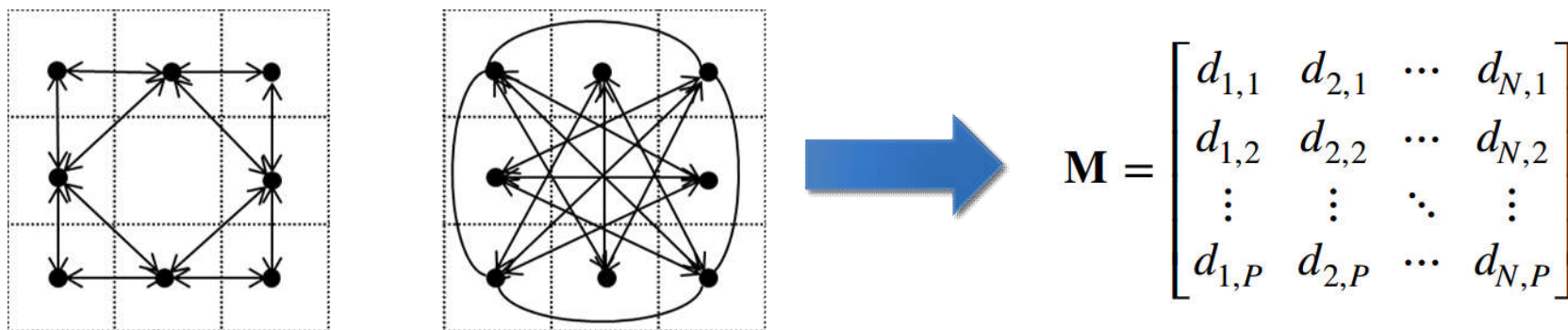

计算相关系数：

$$\gamma(i, j) = \frac{\text{cov}([d_{1,i}, d_{2,i}, \dots, d_{N,i}], [d_{1,j}, d_{2,j}, \dots, d_{N,j}])}{\sqrt{D([d_{2,i}, \dots, d_{N,i}])} \sqrt{D([d_{1,j}, d_{2,j}, \dots, d_{N,j}])}}$$

中值滤波检测流程图

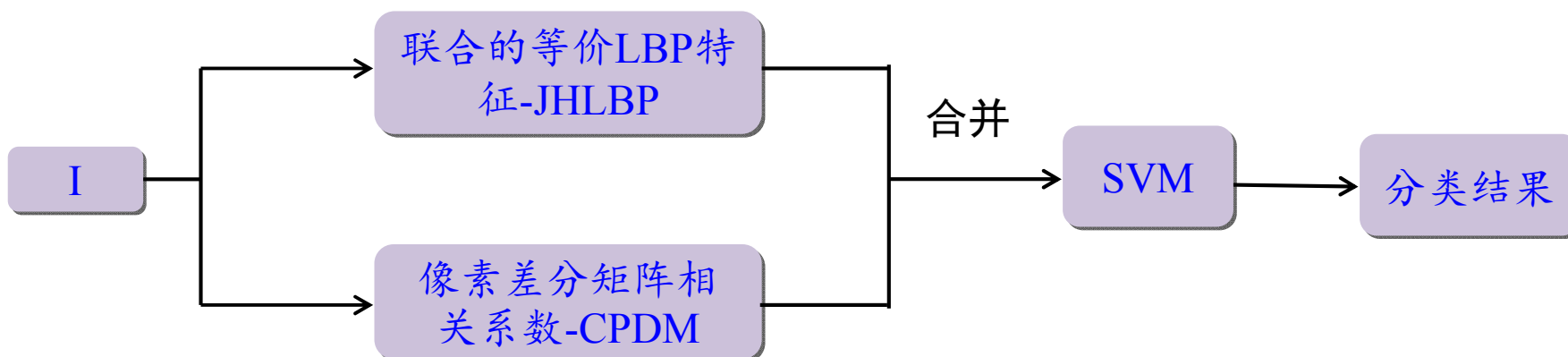

LDD特征性能检测

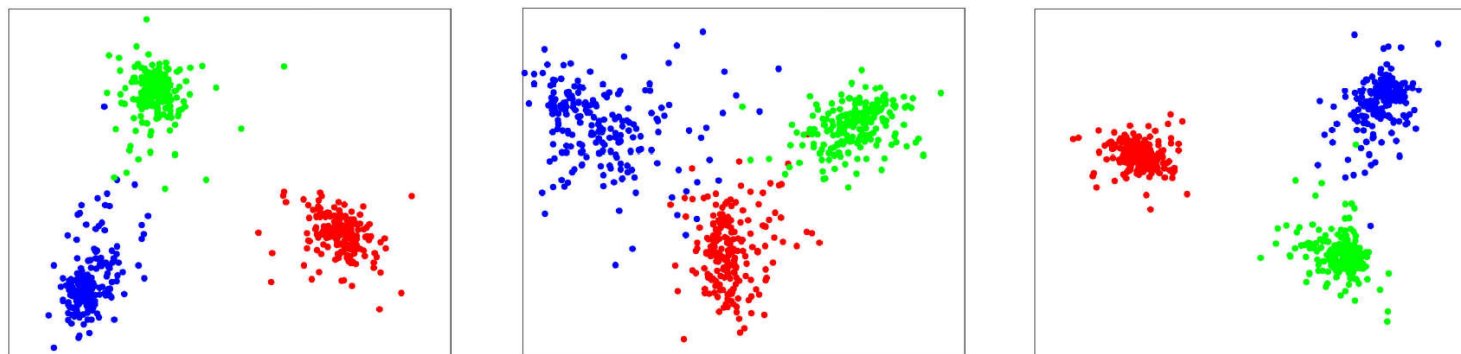

JHLBP

CPDM

LDD

蓝色圆点代表原始图像，红色圆点代表中值滤波图像，绿色圆点代表均值滤波图像
LDD使得类内间距小，类间间距大

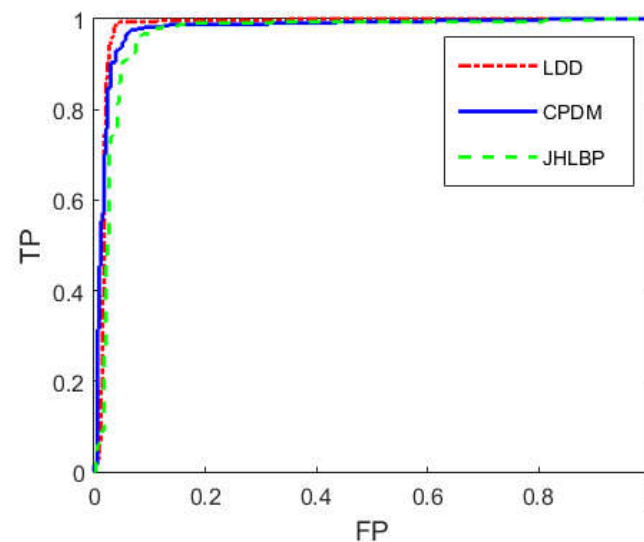
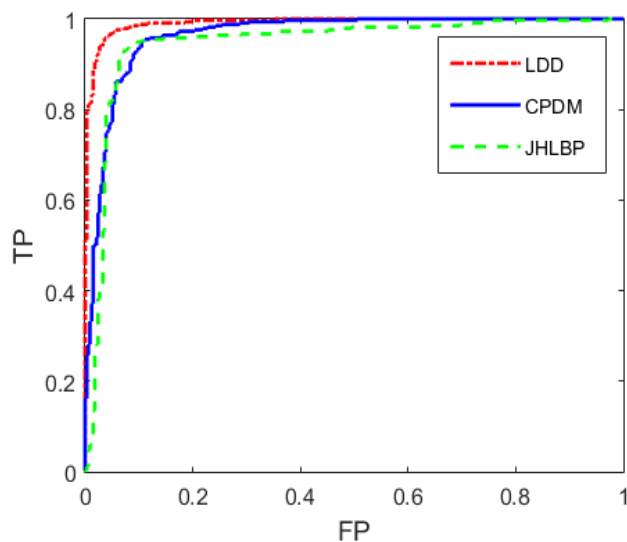



实验结果

➤ 实验设置

- 数据库：UCID, 1338 幅未压缩图像, 分辨率为 512×384 ~ 384×512 ;
- 非中值滤波图像：原始图像, 均值滤波图像, 高斯低通滤波图像, 缩放图像;
- 图像块大小： 256×256 , 128×128 , 64×64 , 32×32 ;
- JPEG质量因子： $QF = 70, 60, 50, 40, 30$.

➤ 性能指标： ROC curve, minimal average decision error p_e

中值滤波图像与原始图像分类ROC曲线

► 检测性能：图像大小为 256×256

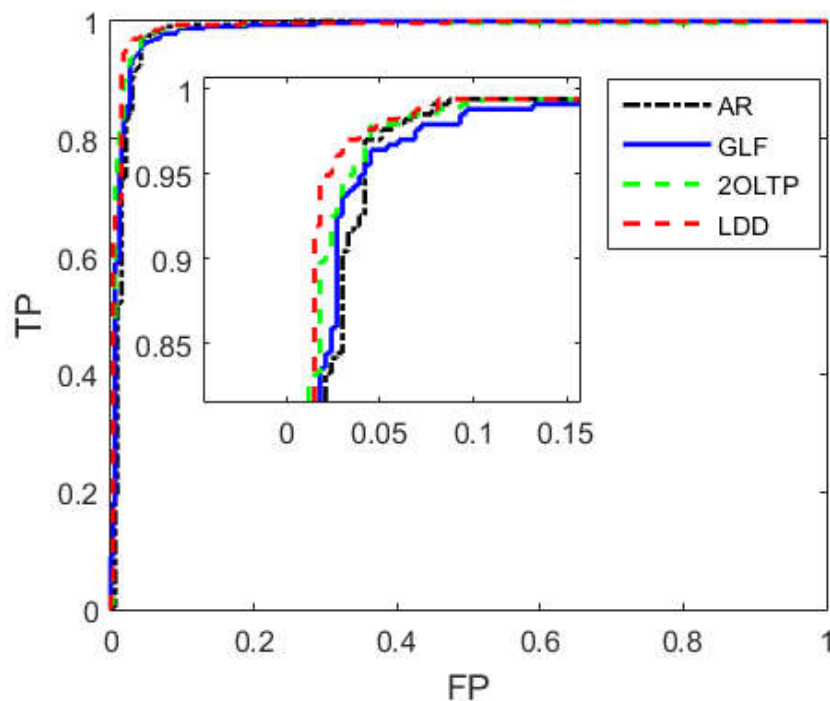

median filtering: 3×3

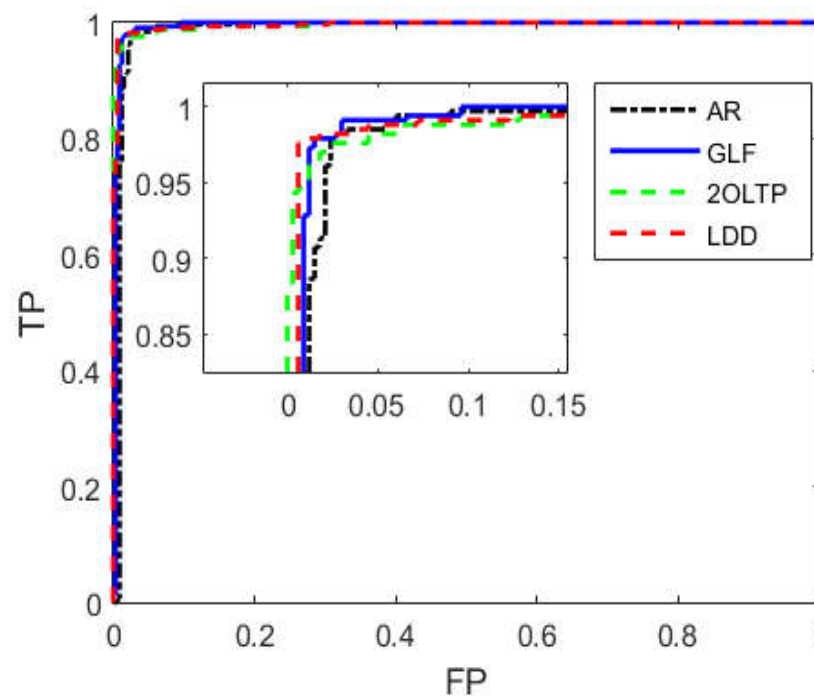

median filtering: 5×5

鲁棒性检测

M	Features	MF3				MF5			
		ORI	GAU	RES	AVE	ORI	GAU	RES	AVE
128	GLF	10.2	11.1	13.2	4.3	5.2	3.9	5.5	2.9
	AR	4.8	9.1	13.4	4.9	7.1	7.2	8.0	2.2
	2OLTP	7.7	6.5	9.2	2.0	4.1	5.8	4.6	0.9
	LDD	6.4	3.3	7.2	1.2	4.3	3.4	4.7	0.9
64	GLF	12.2	14.9	19.1	6.1	6.9	5.4	8.0	3.9
	AR	11.7	10.1	16.3	9.2	8.3	9.7	11.8	3.9
	2OLTP	12.9	9.7	17.5	2.3	7.9	4.7	9.5	1.9
	LDD	10.9	5.8	13.5	1.6	7.6	4.0	9.6	1.1
32	GLF	20.2	18.2	28.1	8.9	10.3	7.7	13.8	5.3
	AR	18.9	16.1	27.5	7.7	16.7	13.0	16.6	5.1
	2OLTP	19.7	14.3	23.1	3.4	11.6	7.2	13.5	3.0
	LDD	17.8	8.1	23.6	3.0	13.4	6.3	15.8	2.3

Features	MF3			MF5		
	QF=50	QF=40	QF=30	QF=50	QF=40	QF=30
GLF	12.1	12.4	13.8	5.1	6.0	6.8
AR	9.1	9.4	10.6	6.9	7.1	7.8
2OLTP	10.7	11.5	13.7	5.4	5.6	7.4
LDD	8.9	9.8	10.1	4.7	5.6	6.4

对JPEG压缩的鲁棒性检测

QF=70,对小尺寸图像块的鲁棒性检测

拼接检测结果



原始图像



中值滤波图像



拼接图像



Ground truth

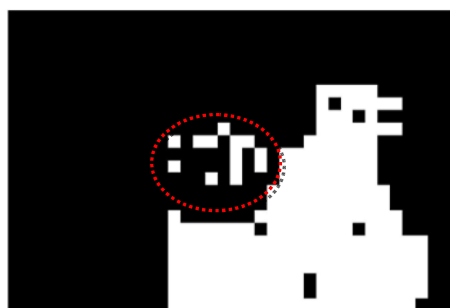

AR

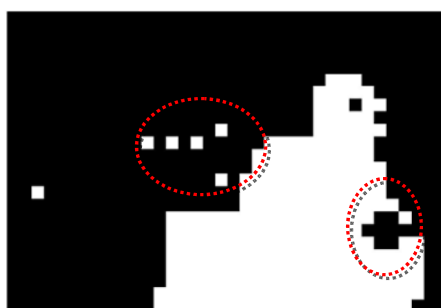

GLF

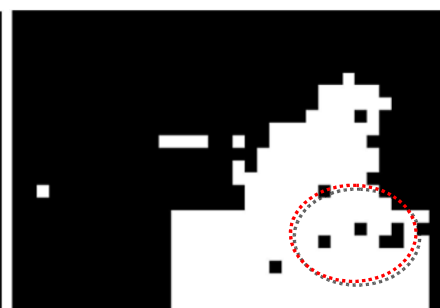

LTP

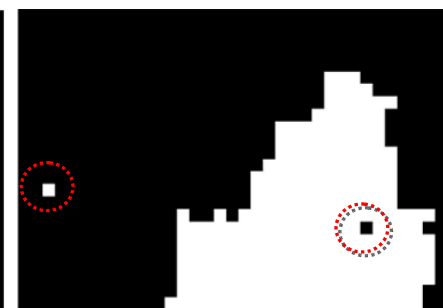

Our

虚警率低

研究内容：基于局部描述子的鲁棒中值滤波检测方法

局部描述子包含两个特征组：
融合的旋转不变特征和差分矩阵系数特征

发表于 Elsevier
Signal Processing: Image
Communication

◆ 旋转不变LBP有效统计图像的局部纹理特征

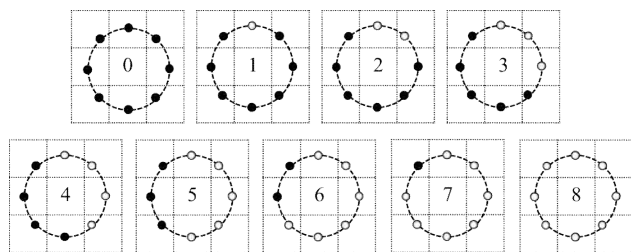

◆ 差分矩阵的相关系数较好的描述由中值滤波操作带来的像素值的变化

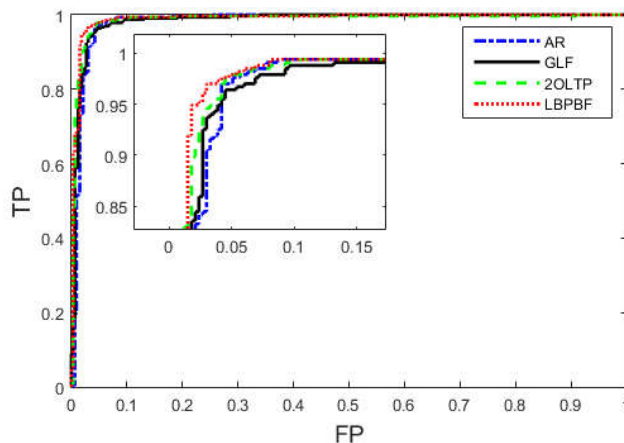
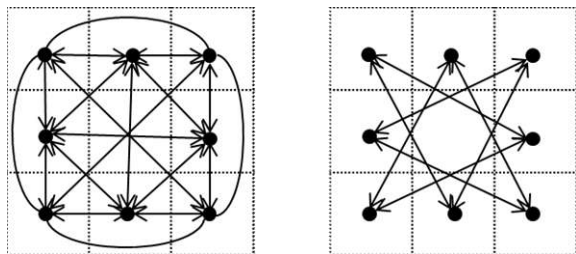

局部描述子的鲁棒性较高，解决小尺寸图像块和低质量压缩因子问题。

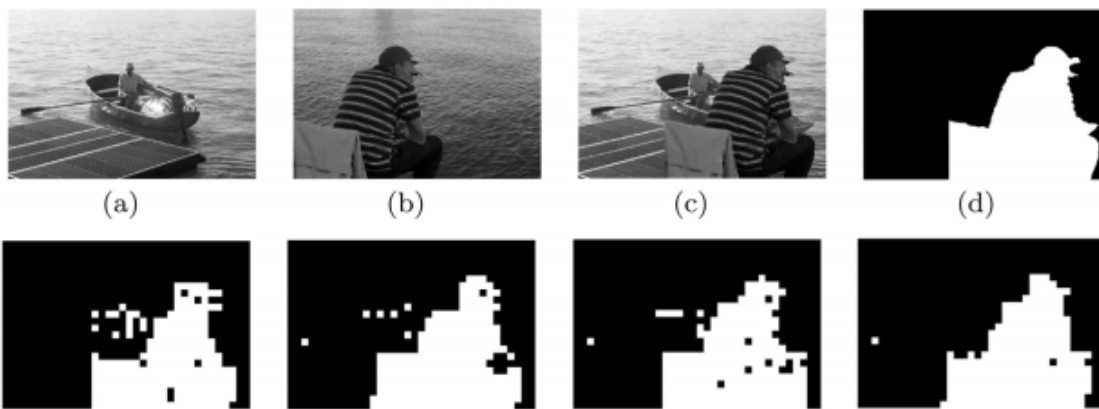



汇报提纲

- 研究背景和研究对象
- 基于峰谷特性的图像对比度增强取证
- 基于局部描述子的鲁棒中值滤波取证
- 基于内容自适应融合残差网络的相机源辨别算法
- 基于卷积神经网络的小尺寸图像中值滤波检测
- 未来工作

研究内容：基于内容自适应融合残差网络的相机源辨别算法

◆ 相机源辨别



◆ 相机模式噪声

- ◆ Lukas J, Fridrich J, Goljan M. Digital camera identification from sensor pattern noise[J]. IEEE Transactions on Information Forensics & Security, 2006, 1(2):205-214.

◆ 深度学习

- ◆ Tuama, A., Comby, F., Chaumont, M. Camera model identification with the use of deep convolutional neural networks. IEEE International Workshop on Information Forensics and Security, 2016.
- ◆ Bondi L, Baroffio L, Guera D, et al. First Steps Towards Camera Model Identification with Convolutional Neural Networks[J]. IEEE Signal Processing Letters, 2016

研究内容：基于内容自适应融合残差网络的相机源辨别算法

◆ 图像内容自适应

$$\begin{cases} T_1(m, v) & m \in [0, 5] \cup [250, 255], v \in [0, 25] \\ T_2(m, v) & m \in [0, 5] \cup [250, 255], v \in (25, 50] \\ T_3(m, v) & m \in (5, 250), v \in [0, 50] \\ & \text{others} \end{cases}$$

内容自适应的CFA插值
以及JPEG压缩操作

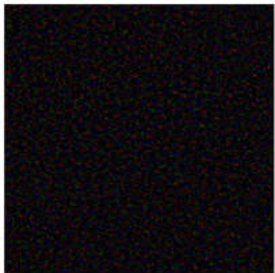
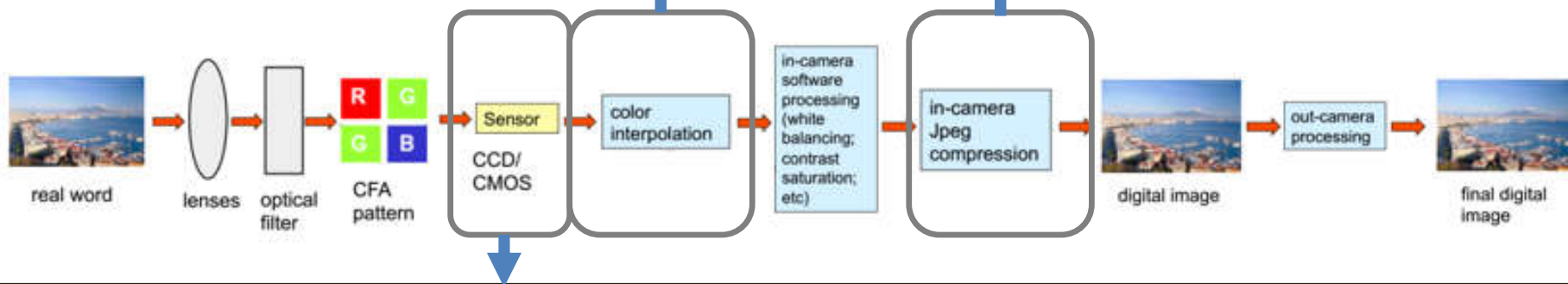

$$\mathbf{I} = \mathbf{I}^{(0)} + \gamma \mathbf{I}^{(0)} \mathbf{K} + \Theta$$

$$\mathbf{W} = \mathbf{I} - \hat{\mathbf{I}}^{(0)} = \gamma \mathbf{I} \mathbf{K} + \Xi$$

$$\frac{\partial^2 L(\mathbf{W}_k / \gamma \mathbf{I}_k | \mathbf{K})}{\partial \mathbf{K}^2} = -\frac{1}{\sigma^2} \sum_{k=1}^N (\mathbf{I}_k)^2$$

$$\text{var}(\hat{\mathbf{K}}) \geq \left(-E \left[\frac{\partial^2 L(\mathbf{K})}{\partial \mathbf{K}^2} \right] \right)^{-1} = \frac{\sigma^2}{\sum_{k=1}^N (\mathbf{I}_k)^2}$$

研究内容：基于内容自适应融合残差网络的相机源辨别算法

◆多尺度空间特征提取及融合

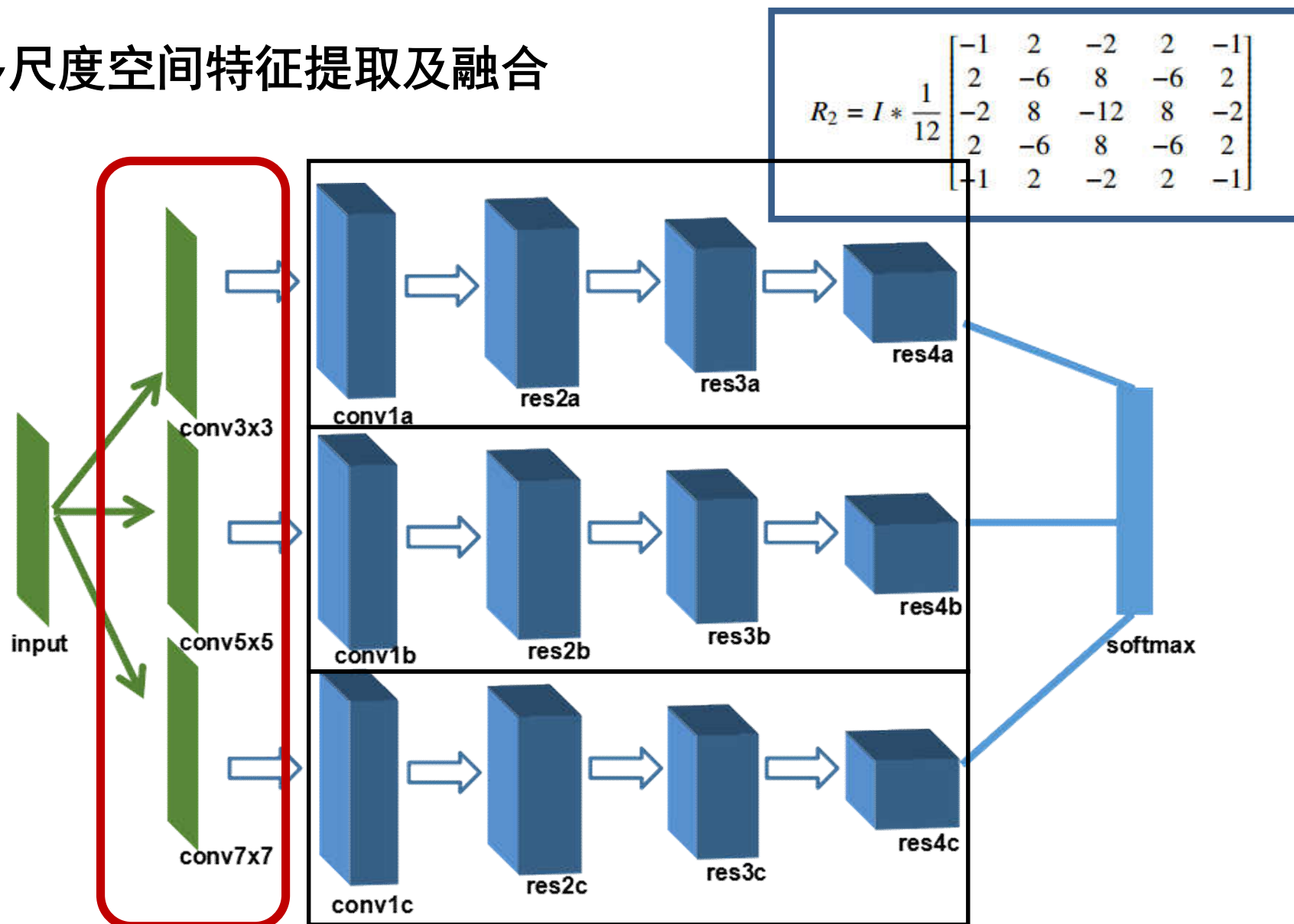

研究内容：基于内容自适应融合残差网络的相机源辨别算法

残差网络 (end-to-end)

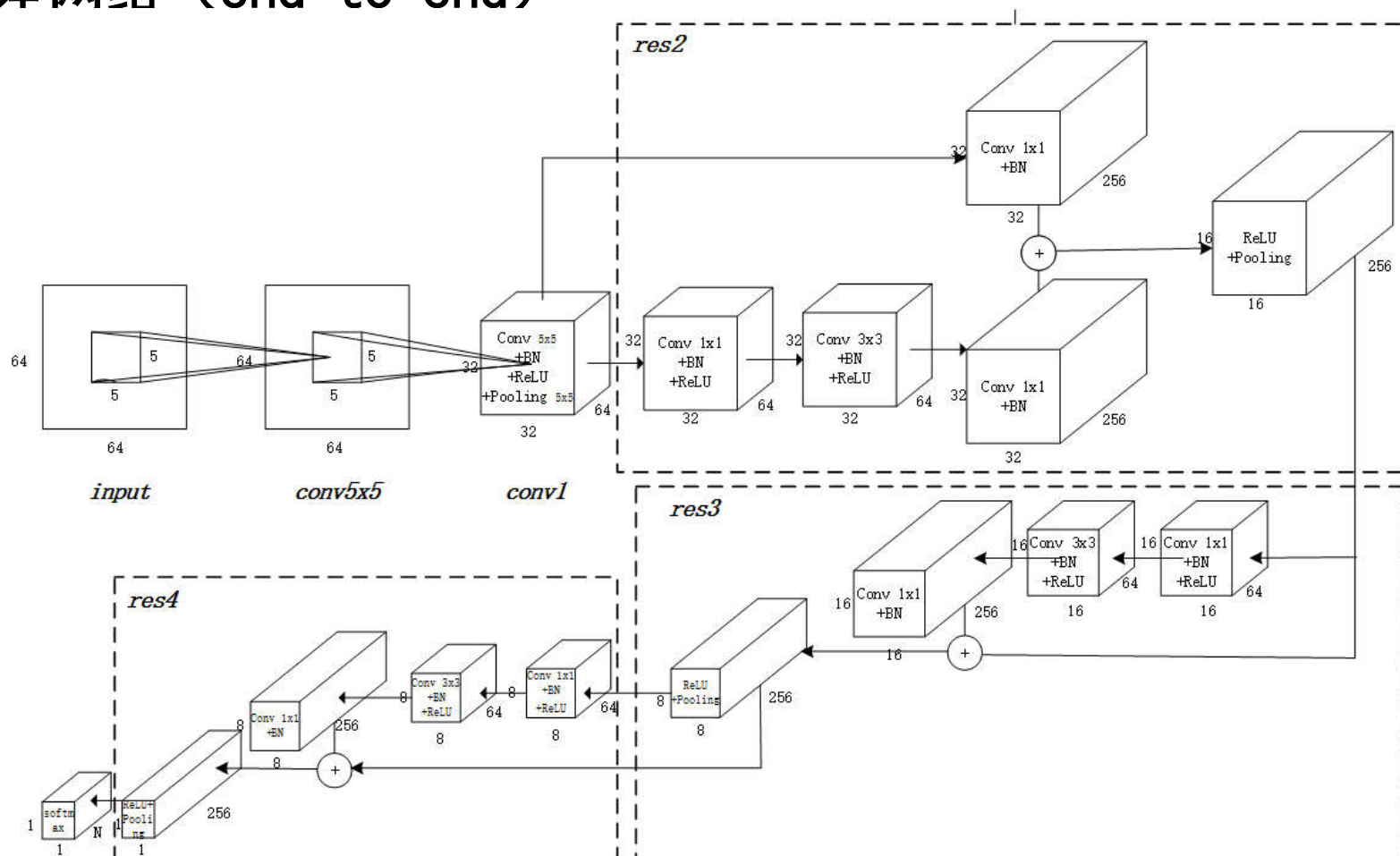

研究内容：基于内容自适应融合残差网络的相机源辨别算法

■ 算法框图

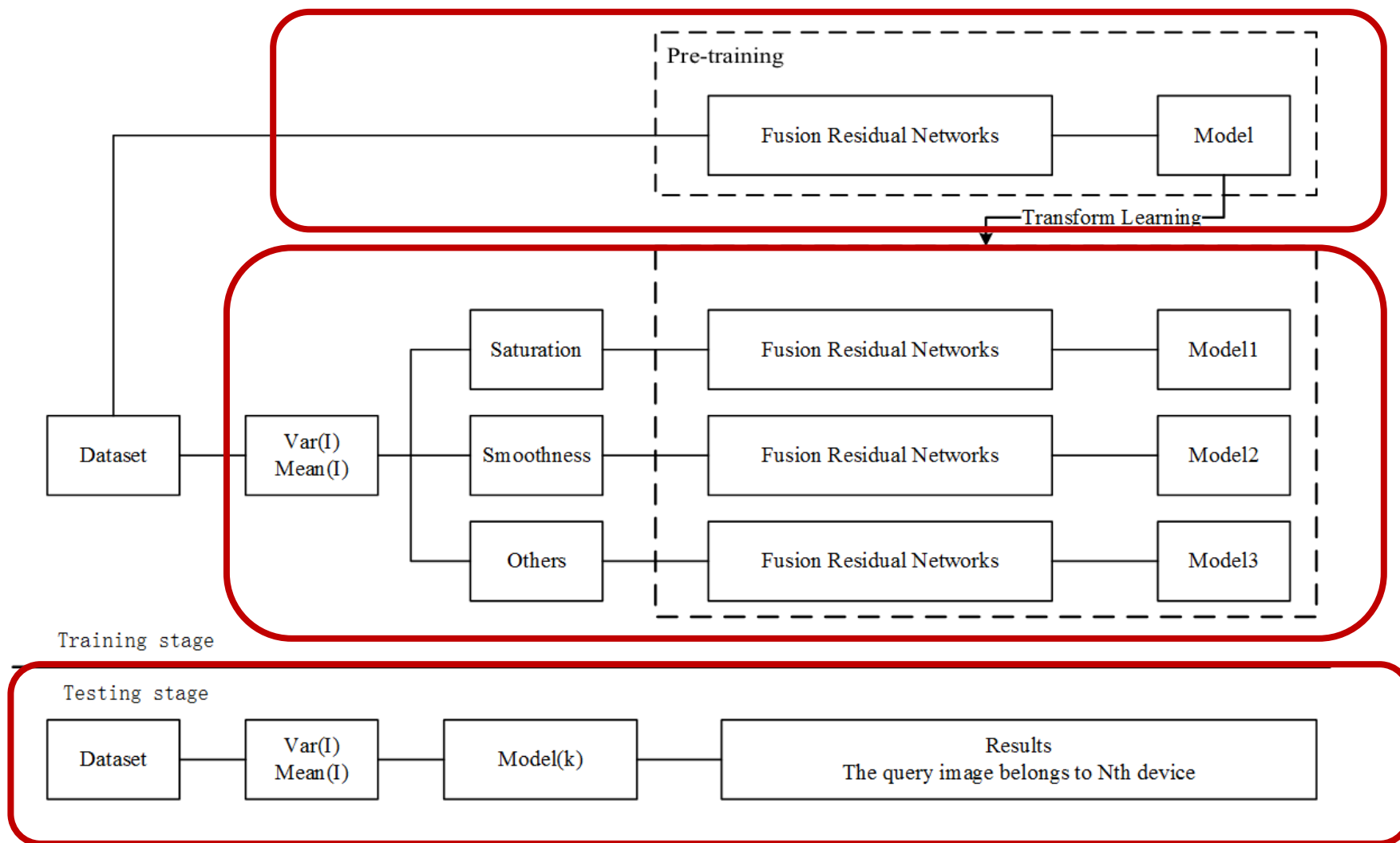

研究内容：基于内容自适应融合残差网络的相机源辨别算法

◆ 实验设置

◆ 数据集

- ◆ Dresden图像库
- ◆ 不重叠的裁剪成64x64大小图像块
- ◆ 训练集：校验集：测试集= 4：1：1

◆ 超参数设置

- ◆ 初始学习率：0.01
- ◆ 学习率每迭代10000次下降10%
- ◆ 动量：0.9
- ◆ 最大迭代次数：500000
- ◆ 权值初始化：均值为0 方差为0.01高斯初始化

Table 2. The list of camera devices used

ID	Camera Devices	Original Resolution
1	Kodak_M1063_0	3664x2748
2	Pentax_OptioA40_0	4000x3000
3	Nikon_CoolPixS710_1	4352x3264
4	Sony_DSC-H50_0	3456x2592
5	Olympus_mju_1050SW_2	3648x2736
6	Panasonic_DMC-FZ50_1	3648x2736
7	Agfa_Sensor530s_0	2560x1920
8	Ricoh_GX100_0	3648x2736
9	Samsung_NV15_0	3648x2736
10	Sony_DSC-W170_0	3648x2736
11	Sony_DSC-T77_0	3648x2736
12	Sony_DSC-T77_1	3648x2736
13	Sony_DSC-T77_2	3648x2736

研究内容：基于内容自适应融合残差网络的相机源辨别算法

◆实验一、相机品牌辨别

Type	Preprocessing	Ave_acc
CA-CNN	HP	81.62%
	Conv 3x3	87.72%
	Conv 5x5	90.11%
	Conv 7x7	90.68%
RN	Conv 3x3	95.58%
	Conv 5x5	96.21%
	Conv 7x7	96.03%
CAF-CNN(Yang et al., 2017)	Conv3 5 7	94.17 %
FRN	Conv3 5 7	96.26%

Table 4. The detection accuracy of content-adaptive fusion residual networks and fusion residual networks. The best results are highlighted in bold

	Smoothness		Saturation		Others	
	FRN	CA-FRN	FRN	CA-FRN	FRN	CA-FRN
1	99.27%	99.09%	84.16%	80.83%	99.13%	99.57%
2	99.03%	99.76%	27.33%	42.55%	97.90%	99.46%
3	93.99%	97.51%	97.66%	93.92%	96.16%	97.49%
4	96.07%	98.02%	51.44%	66.93%	96.82%	95.11%
5	91.14%	89.95%	61.05%	61.18%	96.38%	97.65%
6	94.25%	96.27%	78.45%	85.63%	96.02%	98.19%
7	97.33%	94.9%	20.42%	97.16%	96.38%	98.15%
8	96.96%	98.27%	11.50%	97.08%	97.11%	97.83%
9	96.66%	96.59%	31.40%	46.61%	98.3%	96.95%
AVE	96.14%	96.73%	68.5%	76.89%	97.12%	97.8%

CA-FRN

| Conv3 5 7(Res)

97.03%

研究内容：基于内容自适应融合残差网络的相机源辨别算法

◆实验二、相机型号辨别\相机个体辨别

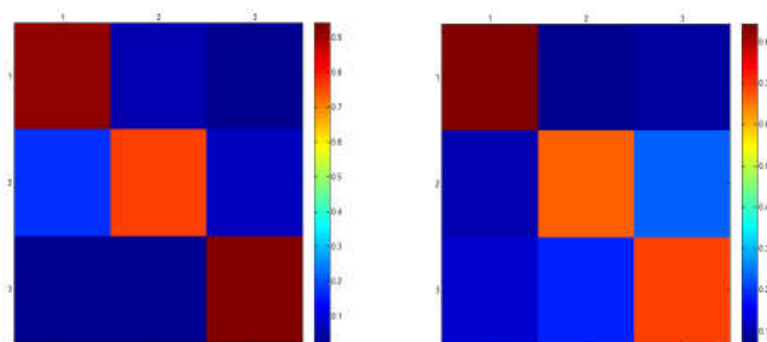

(a)

(b)

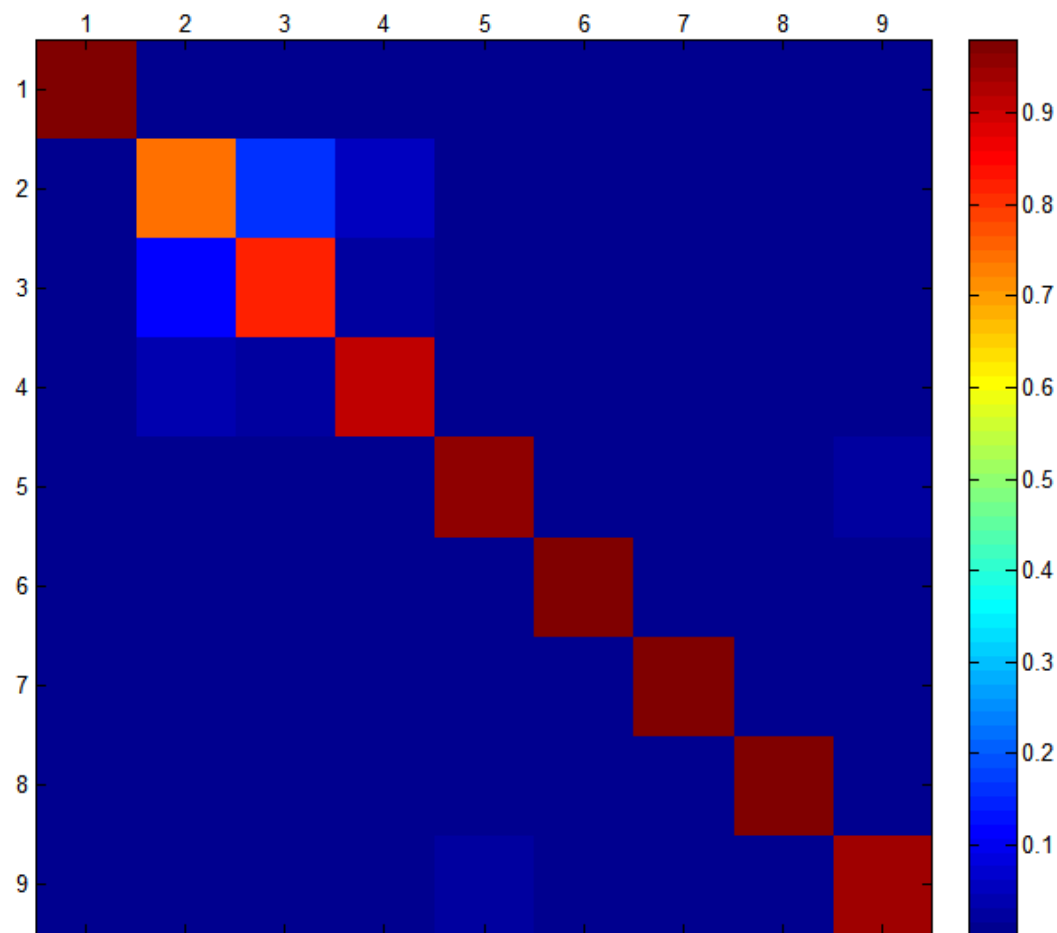

研究内容：基于内容自适应融合残差网络的相机源辨别算法

◆实验三、对比实验（深度学习）

Type	Preprocessing	Ave_acc
CA-CNN	HP	81.62%
	Conv 3x3	87.72%
	Conv 5x5	90.11%
	Conv 7x7	90.68%
GoogleNet(Tuama et al., 2016)	HP	91.60%
ResNet(He et al., 2016)	None	96.20%
RN	Conv 3x3	95.58%
	Conv 5x5	96.21%
	Conv 7x7	96.03%
CAF-CNN(Yang et al., 2017)	Conv3 5 7	94.17 %
FRN	Conv3 5 7	96.26%
CA-FRN	Conv3 5 7(Res)	97.03%

研究内容：基于内容自适应融合残差网络的相机源辨别算法

◆ 实验三、对比实验（相机模式噪声）

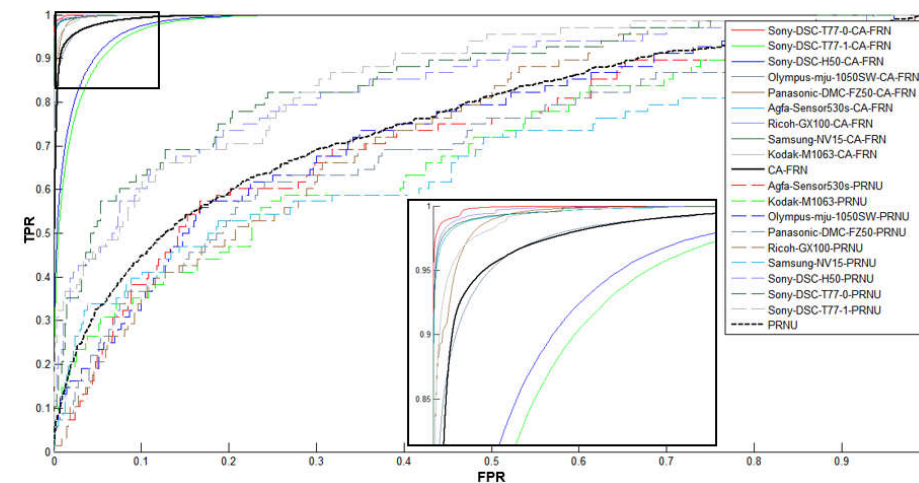
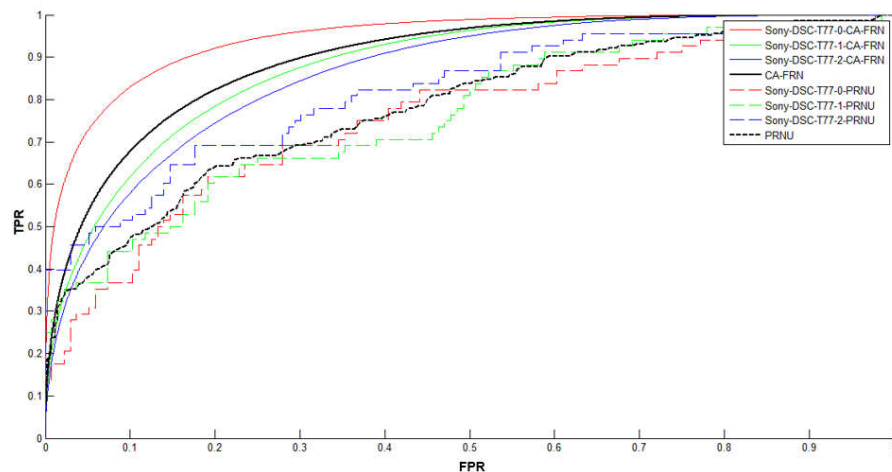
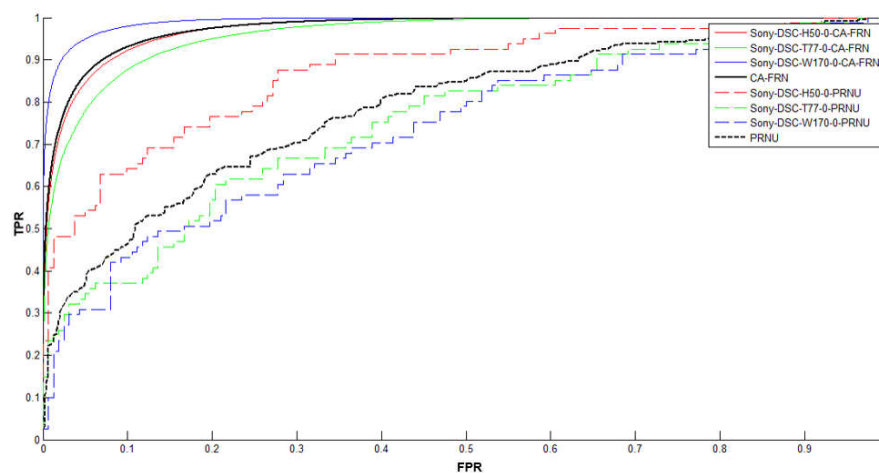
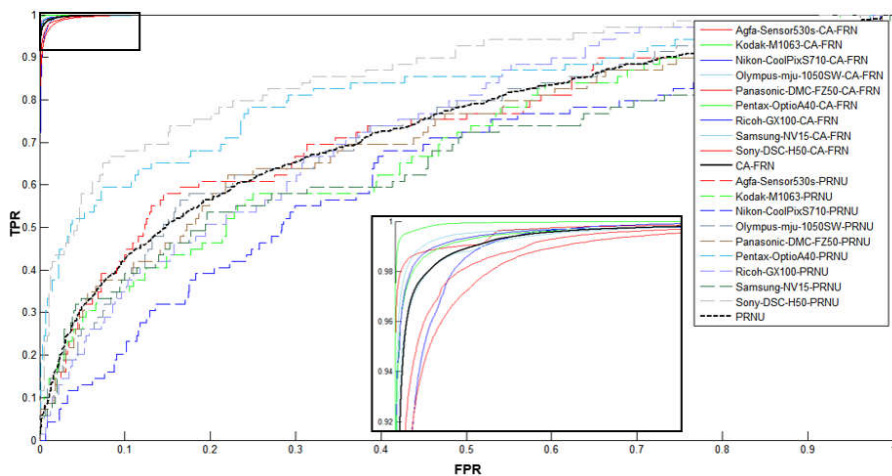

研究内容：基于内容自适应融合残差网络的相机源辨别算法

◆实验四、拼接篡改检测

Tampering Block Size	Cameras	ACC	TPR
64	Kodak_Pentax	99.18%	98%
	Pentax_Kodak	98.34%	100%
128	Kodak_Pentax	99.19%	98.83%
	Pentax_Kodak	98.54%	100%
256	Kodak_Pentax	99.18%	98.96%
	Pentax_Kodak	98.55%	99.96%

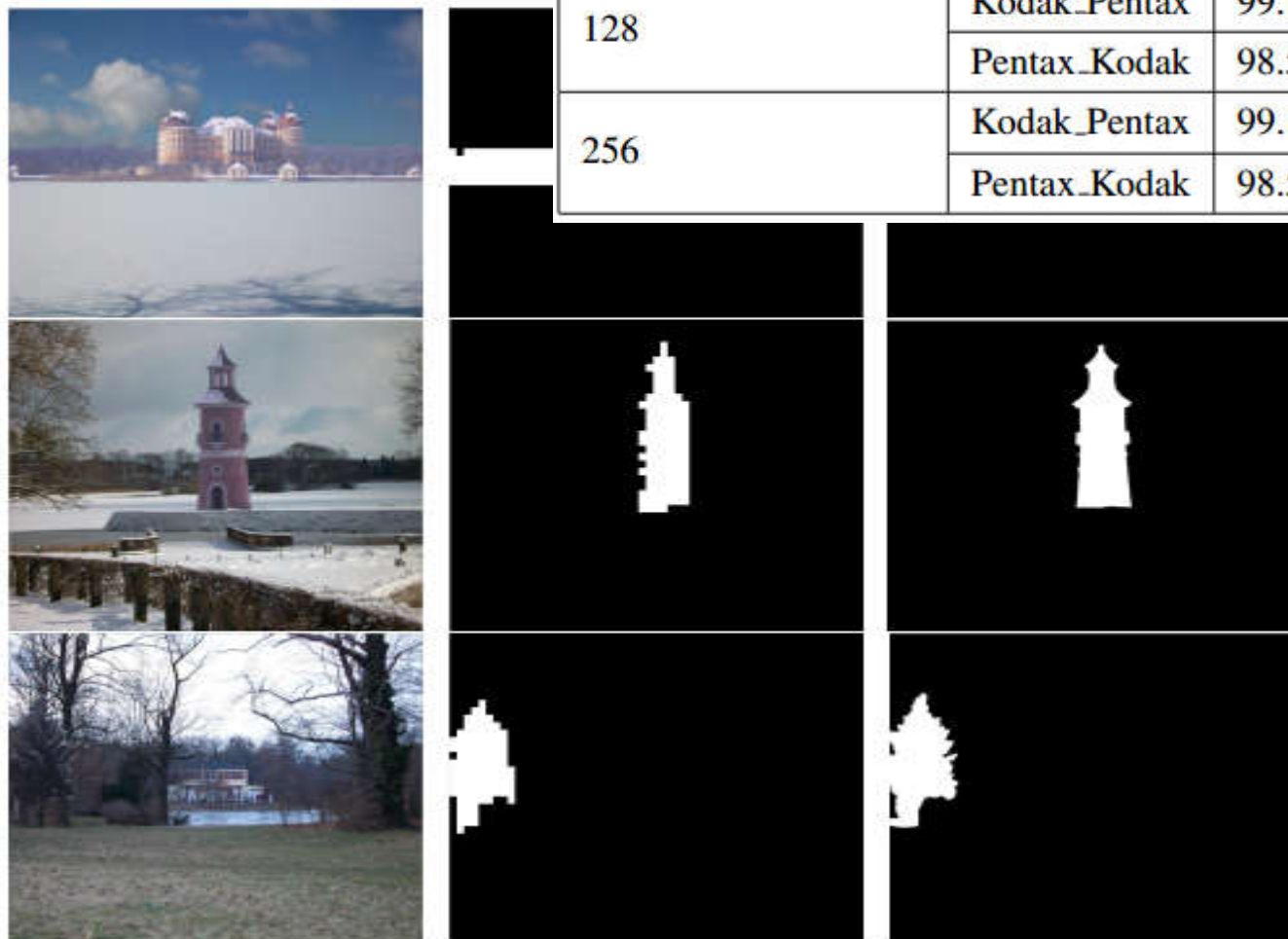

研究内容：基于内容自适应融合残差网络的相机源辨别算法

- ◆ 图像产生过程中，不同图像内容区域会经历不同程度处理，且对相机指纹信号影响不同；

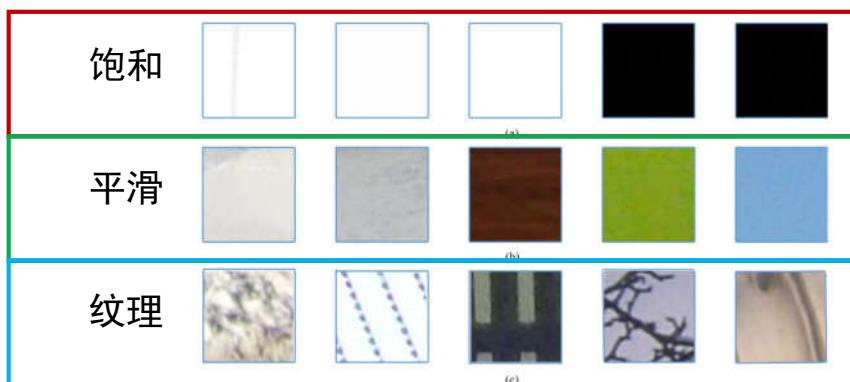

- ◆ 提出了内容自适应融合残差网络；采用多尺度自学习卷积的预处理，并进行网络融合

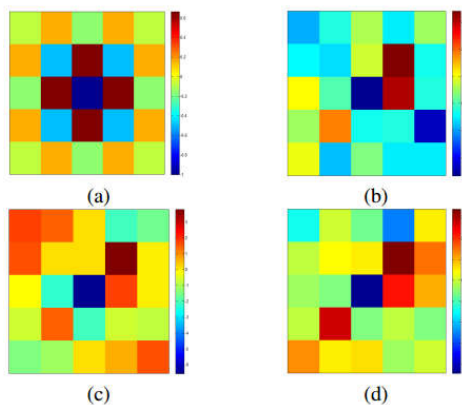

发表于Elsevier
Pattern Recognition Letters

Type	Preprocessing	Ave_acc
CA-CNN	HP	81.62%
	Conv 3x3	87.72%
	Conv 5x5	90.11%
	Conv 7x7	90.68%
GoogleNet(Tuama et al., 2016)	HP	91.60%
ResNet(He et al., 2016)	None	96.20%
RN	Conv 3x3	95.58%
	Conv 5x5	96.21%
	Conv 7x7	96.03%
CAF-CNN(Yang et al., 2017)	Conv3 5 7	94.17 %
FRN	Conv3 5 7	96.26%
CA-FRN	Conv3 5 7(Res)	97.03%

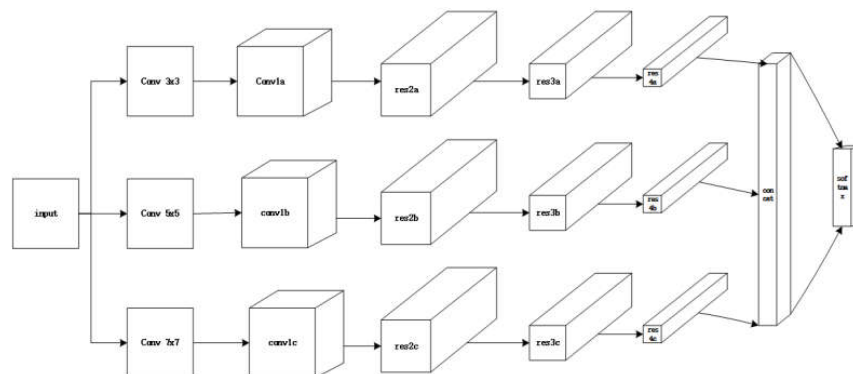



汇报提纲

- 研究背景和研究对象
- 基于峰谷特性的图像对比度增强取证
- 基于局部描述子的鲁棒中值滤波取证
- 基于内容自适应融合残差网络的相机源辨别算法
- 基于卷积神经网络的小尺寸图像中值滤波检测
- 未来工作



研究内容：基于卷积神经网络的小尺寸图像中值滤波检测

■ 研究现状和问题

- ◆ 传统中值检测算法所设计特征表征能力不够充分，且设计特征耗时费力；
- ◆ 小尺寸低质量压缩图像中值滤波检测十分困难；
- ◆ 直接使用卷积神经网络检测中值滤波效果还不够好。

- [1] C. Chen, J. Ni, and J. Huang, “Blind detection of median filtering in digital images: A difference domain based approach,” *IEEE Transactions on Image Processing*, 2013.
- [2] X. Kang, M. C. Stamm, A. Peng, and K. R. Liu, “Robust median filtering forensics using an autoregressive model,” *IEEE Transactions on Information Forensics and Security*, 2013.
- [3] Y. Zhang, S. Li, S. Wang, and Y. Q. Shi, “Revealing the traces of median filtering using high-order local ternary patterns,” *IEEE Signal Processing Letters*, vol, 2014.
- [4] J. Chen, X. Kang, Y. Liu, and Z. Wang, “Median filtering forensics based on convolutional neural networks.” *IEEE Signal Processing Letters*, vol. 22, Nov. 2015.

研究内容：基于卷积神经网络的小尺寸图像中值滤波检测

■ 提出预处理层：放大



研究内容：基于卷积神经网络的小尺寸图像中值滤波检测

■ 预处理层：放大层

最近邻插值

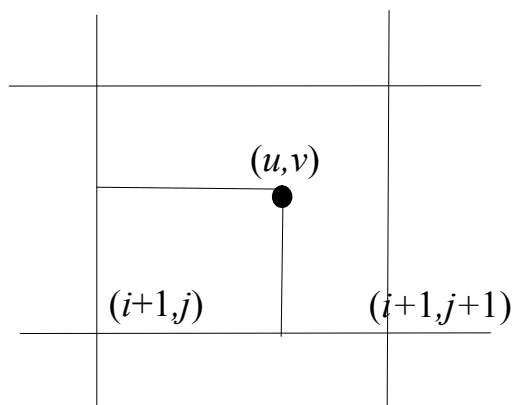

$$D[(u, v), (i, j)] = \min \{ D[(u, v), (i, j)], D[(u, v), (i, j+1)], \\ D[(u, v), (i+1, j)], D[(u, v), (i+1, j+1)] \}$$

8	9	3
9	6	5
1	1	10

放大2倍

8	8	9	9	3	3
8	8	9	9	3	3
9	9	6	6	5	5
9	9	6	6	5	5
1	1	1	1	10	10
1	1	1	1	10	10

不引入新的灰度值，对于中值滤波痕迹破坏小

研究内容：基于卷积神经网络的小尺寸图像中值滤波检测

■ 放大前后原始图像和中值滤波图像之间特征差异变化

$$Dif = Feature(abs(Fourier(med(x)))) - Feature(abs(Fourier(x)))$$

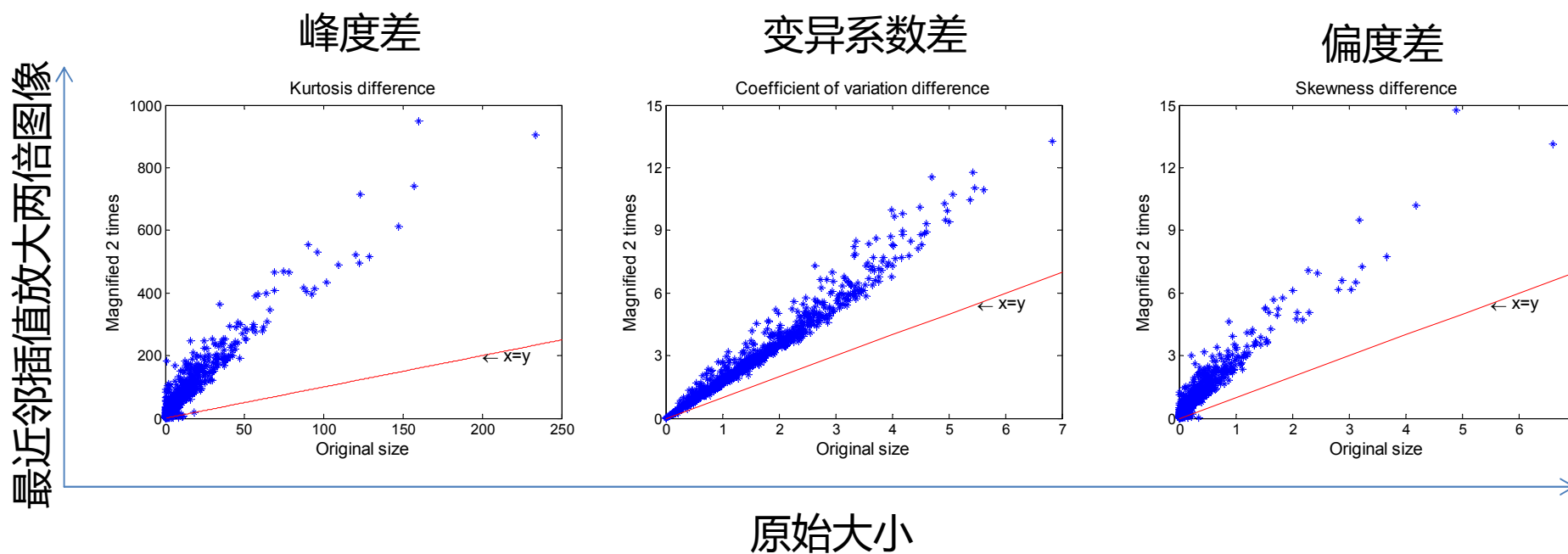

放大后原始图像和中值滤波图像类间差异明显，更容易区分

研究内容：基于卷积神经网络的小尺寸图像中值滤波检测

■ 融合Mlpconv-layer

中值滤波非线性滤波——增强网络非线性

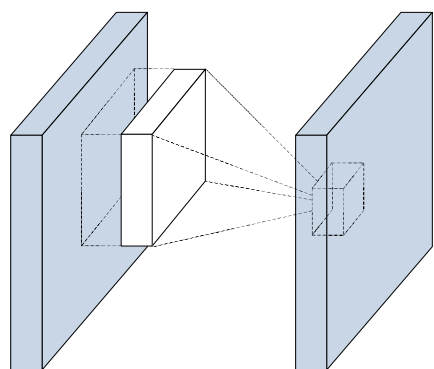

Traditional conv-layer

$$x_k^l = \sum_{i=1}^{i=K^{l-1}} x_i^{l-1} * W_{k,i}^l + b_k^l$$

$$f_k = \max(x_k, 0)$$

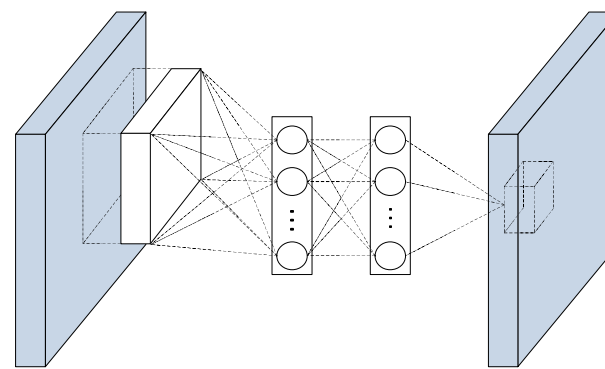

Mlpconv-layer

$$f_{i,j_1}^1 = \max\left(\sum x_i * w_{j_1}^1 + b_{j_1}, 0\right)$$

$$\vdots$$

$$f_{i,j_n}^n = \max\left(\sum f_i^{n-1} * w_{j_n}^n + b_{j_n}, 0\right)$$

研究内容：基于卷积神经网络的小尺寸图像中值滤波检测

■ 融合Mlpconv-layer

中值滤波非线性滤波——增强网络非线性

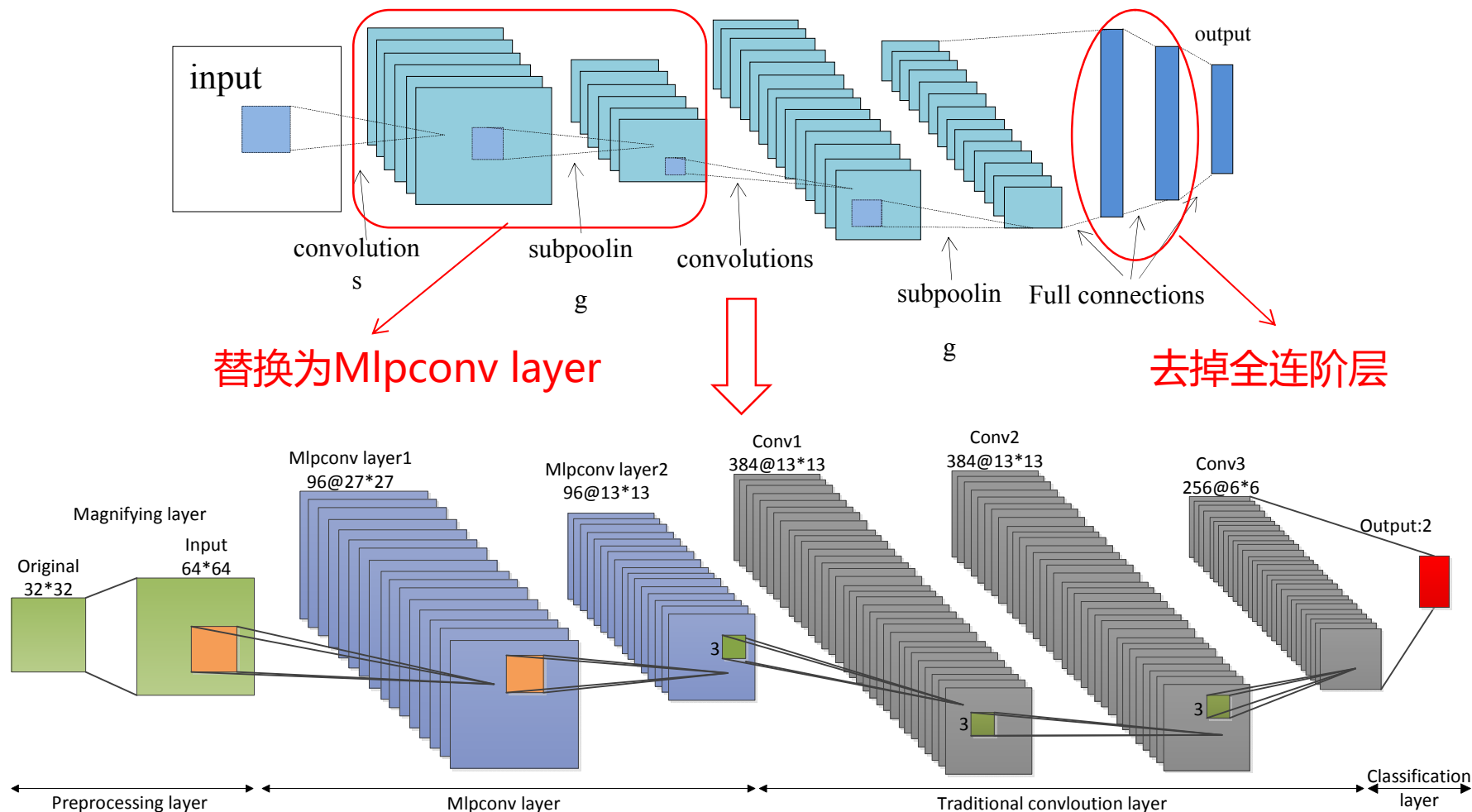

研究内容：基于卷积神经网络的小尺寸图像中值滤波检测

网络模型MFNet

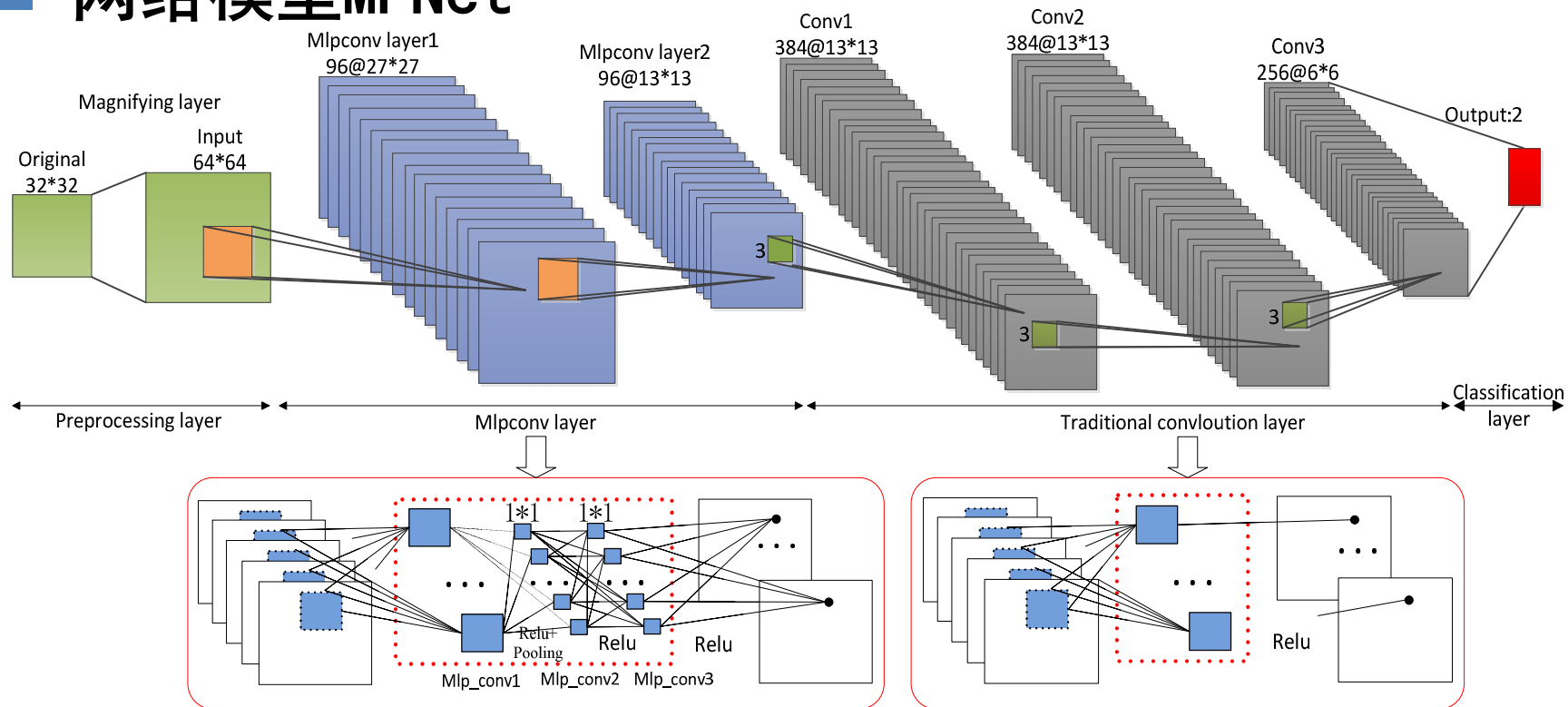

Method	No mlpconv	One mlpconv	Two mlpconv	Three mlpconv	Four mlpconv
Accuracy	82.53	83.77	84.10	83.85	83.54

研究内容：基于卷积神经网络的小尺寸图像中值滤波检测

网络模型MFNet

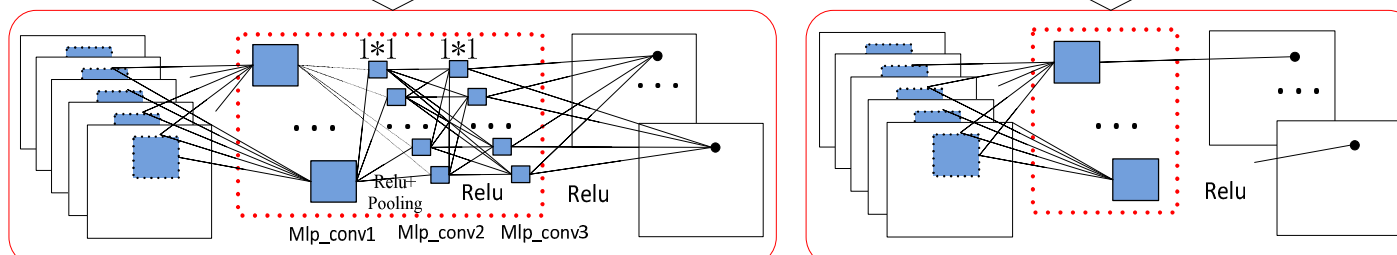
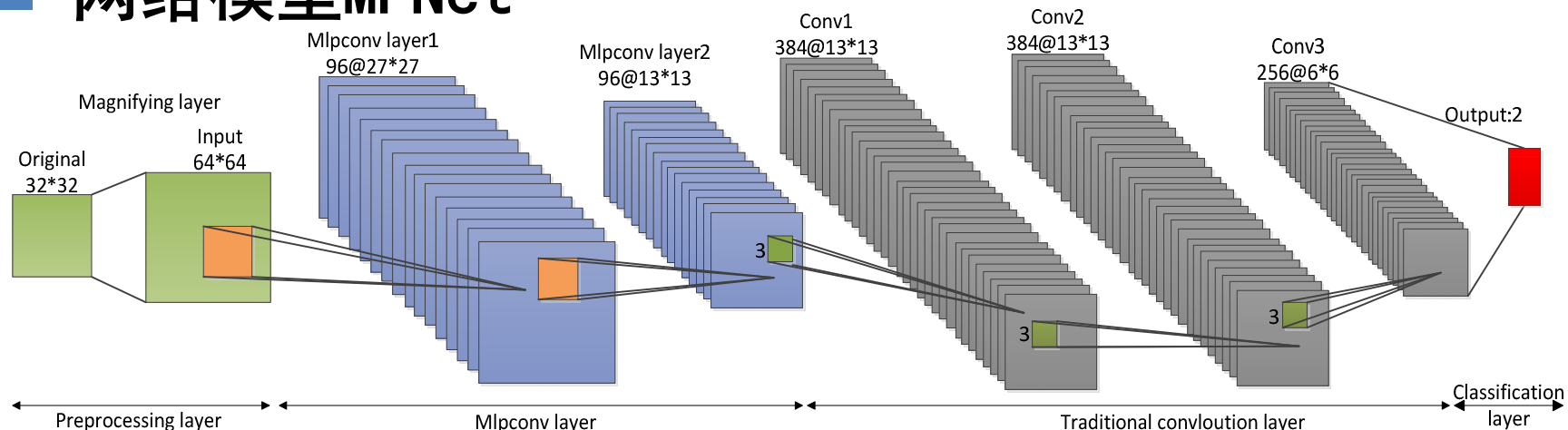

Input size	Mlpconv layer1				Mlpconv layer2			
	Mlp1_Conv1	Pool1	Mlp1_Conv2	Mlp1_Conv3	Mlp2_Conv1	Pool2	Mlp2_Conv2	Mlp2_Conv3
64×64	Kernel:11 Stride:1 Pad:1 Num_out:96	Kernel:3 Stride:2	Kernel:1 Stride:1 Num_out:96	Kernel:1 Stride:1 Num_out:96	Kernel:5 Stride:1 Pad:2 Num_out:256	Kernel:3 Stride:2	Kernel:1 Stride:1 Num_out:96	Kernel:1 Stride:1 Num_out:96



研究内容：基于卷积神经网络的小尺寸图像中值滤波检测

数据库构成和实验设置

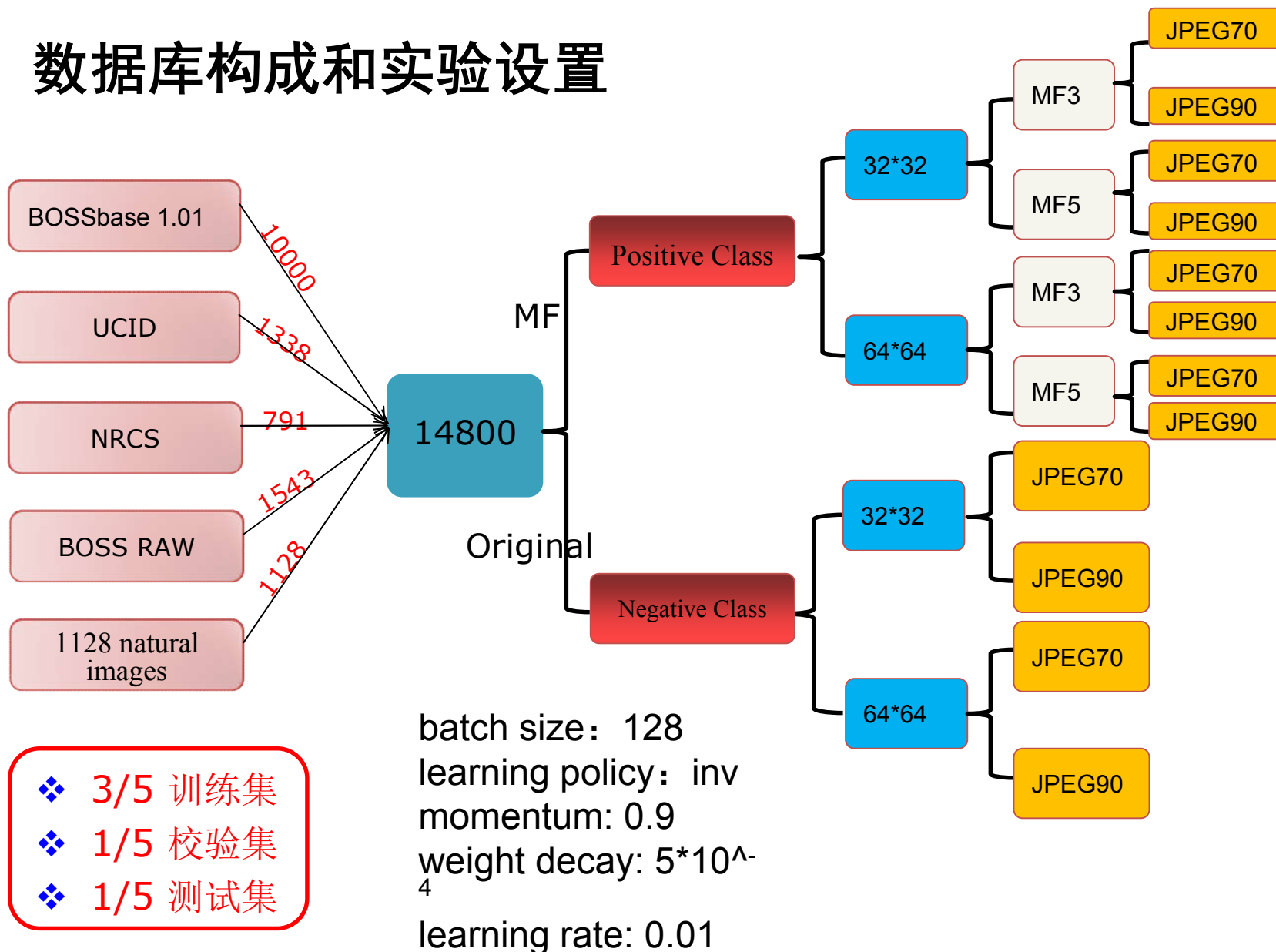

研究内容：基于卷积神经网络的小尺寸图像中值滤波检测

■ 原始尺寸图像块输入，验证所提网络有效性

Image size	Input	Method	JPEG70 vs. MF3+JPEG70	JPEG70 vs. MF5+JPEG70	JPEG90 vs. MF3+JPEG90	JPEG90 vs. MF5+JPEG90
64×64	MFR	Chen [21]	86.62	92.37	93.28	94.56
		Proposed	89.49	93.81	95.30	95.62
	Image	Proposed	89.96	94.20	95.18	95.51
32×32	MFR	Chen [21]	79.01	84.50	88.39	90.24
		Proposed	82.30	87.33	90.91	92.97
	Image	Proposed	84.10	89.58	91.50	93.57

$$MFR = med_w(x(i, j)) - x(i, j)$$

[21] J. Chen, X. Kang, Y. Liu, and Z. Wang, “Median filtering forensics based on convolutional neural networks,” *IEEE Signal Processing Letters*, vol. 22, Nov. 2015.

研究内容：基于卷积神经网络的小尺寸图像中值滤波检测

■ 验证最近邻放大的有效性

最近邻插值放大2倍图像块，将网络最后一层特征可视化

放大前

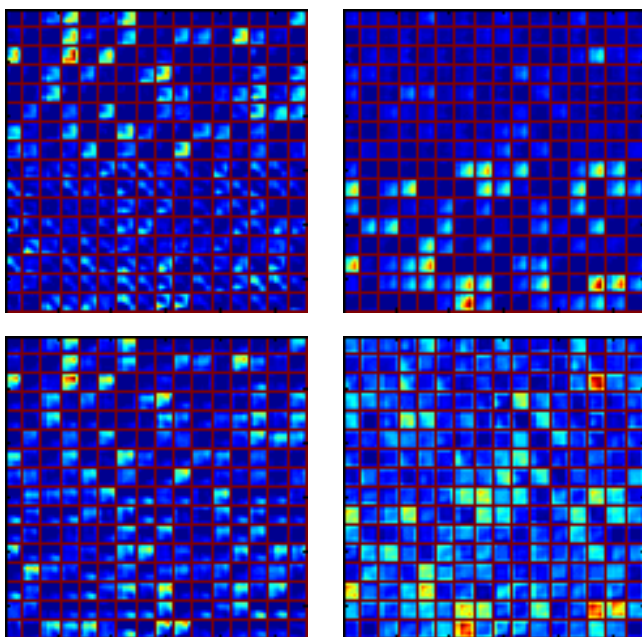

原始图像

中值滤波图像

放大后

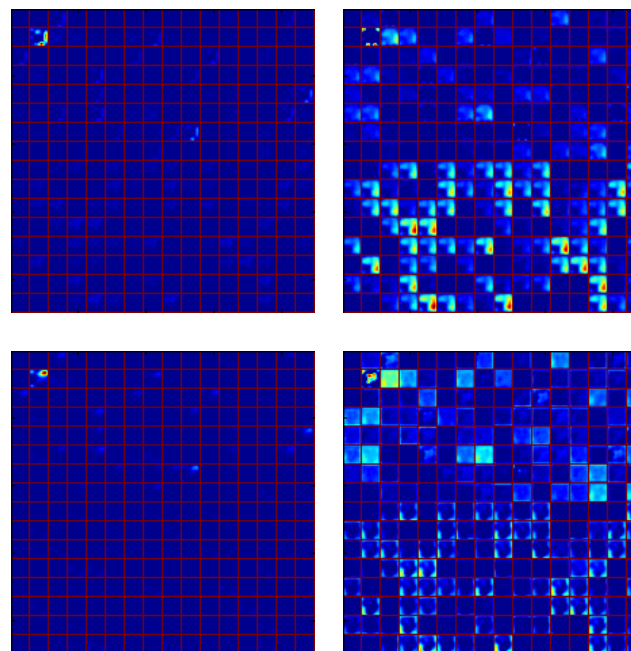

原始图像

中值滤波图像

研究内容：基于卷积神经网络的小尺寸图像中值滤波检测

■ 验证最近邻放大有效性

32*32及对应放大图像块输入

Method	Magnification Times	JPEG70 vs. MF3+JPEG70	JPEG70 vs. MF5+JPEG70	JPEG90 vs. MF3+JPEG90	JPEG90 vs. MF5+JPEG90
Proposed	1 (32×32)	84.10	89.58	91.50	93.57
	2 (64×64)	85.23	91.67	93.06	95.71
	3 (96×96)	85.67	91.87	93.34	96.23
	4 (128×128)	85.68	91.92	93.95	96.32
Chen [21]	MFR(32×32)	79.01	84.50	88.39	90.24

64*64和16*16及对应放大图像块输入

Magnification Times	JPEG70 vs. MF3+JPEG70	JPEG70 vs. MF5+JPEG70	JPEG90 vs. MF3+JPEG90	JPEG90 vs. MF5+JPEG90
1 (64×64)	89.96	94.20	95.18	95.51
2 (128×128)	91.07	94.86	95.97	96.62
1 (16×16)	73.46	81.87	81.28	86.33
2 (32×32)	77.04	84.86	86.42	90.67

研究内容：基于卷积神经网络的小尺寸图像中值滤波检测

◆ 提出了一种针对中值滤波检测的CNN模型-MFNet

◆ 采用最近邻插值放大原始图像和中值滤波图像类间差异

◆ 融合Mlpconv layer提升网络非线性表征能力

被录用 Elsevier Journal of Visual Communication and Image Representation

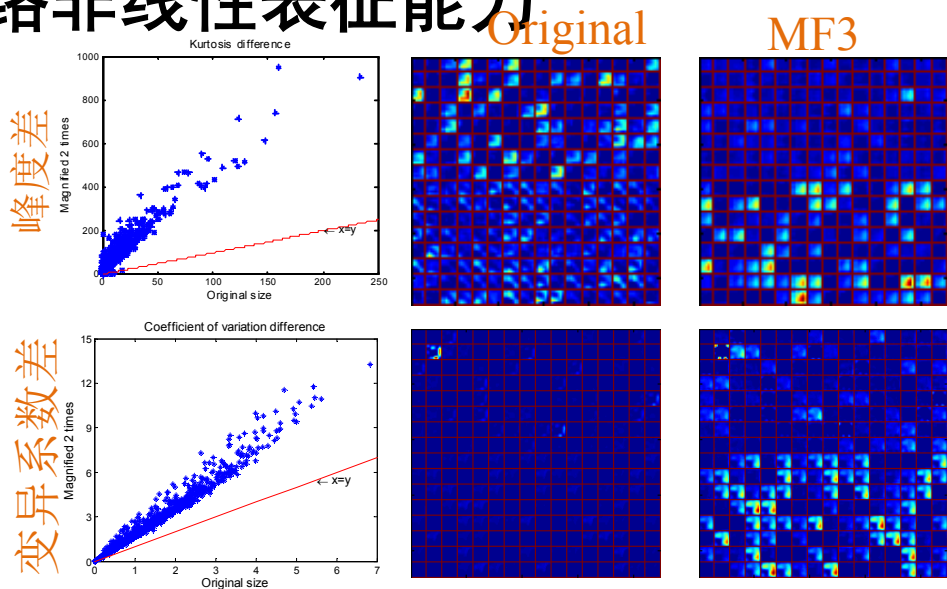
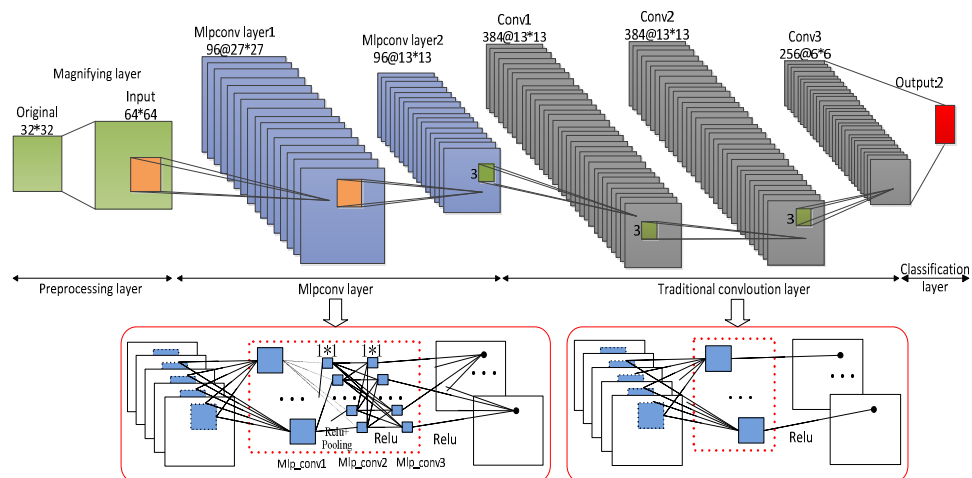

Magnification Times	JPEG90 vs. MF5+JPEG90
1 (32×32)	93.57
2 (64×64)	95.71
3 (96×96)	96.13
4 (128×128)	96.32



未来工作

- 设备源的取证
- 更实用的操作类别的辨识
- 拼接检测以及关联性分析



总结

- 背景介绍和研究对象
- 传统模式识别方法
 - 基于峰谷特性的图像对比度增强取证
 - 基于局部描述子的鲁棒中值滤波取证
- 基于深度学习的识别方法
 - 基于内容自适应融合残差网络的相机源辨别算法
 - 基于卷积神经网络的小尺寸图像中值滤波检测
- 未来工作



谢谢各位的聆听！
